

Report on the investigation of  
wave damage to the  
passenger cruise ship  
***Oriana***  
in the North Atlantic Ocean  
28 September 2000

Marine Accident Investigation Branch  
First Floor  
Carlton House  
Carlton Place  
Southampton  
United Kingdom  
SO15 2DZ

**Report No 36/2002  
November 2002**

**Extract from**  
**The Merchant Shipping**  
**(Accident Reporting and Investigation)**  
**Regulations 1999**

The fundamental purpose of investigating an accident under these Regulations is to determine its circumstances and the cause with the aim of improving the safety of life at sea and the avoidance of accidents in the future. It is not the purpose to apportion liability, nor, except so far as is necessary to achieve the fundamental purpose, to apportion blame.

# CONTENTS

|  | Page   |
|--|--|
| <b>GLOSSARY OF ABBREVIATIONS, ACRONYMS AND TERMS</b> |  |
| <b>SYNOPSIS</b>                                      | <b>1</b>   |
| <b>SECTION 1 - FACTUAL INFORMATION</b>               | <b>2</b>   |
| 1.1 Particulars of <i>Oriana</i> and accident        | 2  |
| 1.2 Narrative  | 3  |
| 1.3 Injuries to personnel and damage                 | 7  |
| 1.4 Onboard weather monitoring                       | 9  |
| 1.5 Storm warnings                                   | 14   |
| 1.6 Ship's motion and wave heights                   | 14   |
| 1.7 The windows                                      | 18   |
| 1.8 Window defects                                   | 28   |
| 1.9 Storm covers                                     | 31   |
| 1.10 Vessel condition                                | 34   |
| 1.11 Action taken regarding yacht in distress        | 34   |
| 1.12 Action taken following the accident             | 34   |
| <b>SECTION 2 - ANALYSIS</b>                          | <b>40</b>  |
| 2.1 Window design                                    | 40   |
| 2.2 Window defects                                   | 40   |
| 2.3 Failure mechanism                                | 43   |
| 2.4 Storm avoidance                                  | 43   |
| 2.5 Safety considerations                            | 45   |
| 2.6 Risk to personnel                                | 46   |
| 2.7 Storm covers                                     | 46   |
| 2.8 Damage repairs                                   | 47   |
| 2.9 Remedial action                                  | 48   |
| 2.10 Actions taken following the accident            | 48   |
| 2.11 Trends in ship's window design                  | 48   |
| <b>SECTION 3 - CAUSE</b>                             | <b>49</b>  |
| 3.1 Immediate cause:                                 | 49   |
| 3.2 Contributing factors:                            | 49   |
| 3.3 Other findings:                                  | 50   |
| <b>SECTION 4 - RECOMMENDATIONS</b>                   | <b>52</b>  |
| <b>Appendix</b>                                      |  |
| <b>Figure 1</b>                                      | <b>Diagram showing <i>Oriana</i>'s deck layout</b>                                     |
| <b>Figure 2</b>                                      | <b>Extract of BA Chart 4004 showing the tracks of <i>Oriana</i> and the depression</b> |

- Figure 3** Photograph of distorted bulkhead
- Figure 4** Photograph of damaged ceiling
- Figure 5** Photograph of damaged bathroom module
- Figure 6** MO Surface Analysis for 1200 on 27 September 2000
- Figure 7** MO Surface Analysis for 1200 on 28 September 2000
- Figure 8** Photograph showing waves coming from the port quarter
- Figure 9** Photograph of a wave breaking
- Figure 10** Photograph of a plume of spray on the port side at deck 7
- Figure 11** Photograph of a wave of a similar height to deck 7
- Figure 12** Diagram showing Significant Wave Heights for 00Z on 28 September 2000
- Figure 13** Diagram showing Significant Wave Heights for 12Z on 28 September 2000
- Figure 14** Drawing of Het Anker Type 507 window
- Figure 15** Drawing of Het Anker Type 606 window
- Figure 16** Welding instructions issued by Het Anker
- Figure 17** Photograph showing the positions of the damaged windows
- Figure 18** Diagram showing the positions of the damaged cabins
- Figure 19** Photograph of glass pane found intact
- Figure 20** Photograph of a temporary repair to a damaged window
- Figure 21** Diagram showing gap caused by poor fitting gasket
- Figure 22** Diagram of the securing arrangements for storm covers
- Figure 23** Photograph of a storm cover in position
- Figure 24** Photograph of ruptured sockets
- Figure 25** Diagram of a retaining plate
- Figure 26** Photograph of window fitted with retaining plates
- Figure 27** Lloyd's Register Marine Technical Notice
- Figure 29** Lloyd's Register survey procedure for windows at Het Anker
- Figure 28** Illustration of hogging

## **GLOSSARY OF ABBREVIATIONS AND ACRONYMS**

|         |   |  |
|---------|---|--|
| BA      | - | British Admiralty                      |
| BSMA 25 | - | British Standard - Marine Series No 25 |
| ETA     | - | Estimated Time Of Arrival              |
| FWOC    | - | Fleet Weather and Oceanographic Centre |
| ISO     | - | International Standards Organisation   |
| IMO     | - | International Maritime Organisation    |
| kW      | - | Kilowatts                              |
| kt      | - | knot                                   |
| m       | - | metres                                 |
| mb      | - | millibar                               |
| MCA     | - | Maritime and Coastguard Agency         |
| MSA     | - | Marine Safety Agency                   |
| MHz     | - | Megahertz                              |
| mm      | - | millimetres                            |
| MO      | - | Meteorological Office                  |
| MRCC    | - | Maritime Rescue Co-ordination Centre   |
| nm      | - | nautical mile                          |
| NWS     | - | National Weather Service               |
| OOW     | - | Officer of the Watch                   |
| RFI     | - | Radio France Internationale            |
| RN      | - | Royal Navy                             |
| US      | - | United States                          |
| UTC     | - | Universal Co-ordinated Time            |

## GLOSSARY OF TERMS

- B-0 fire rating - Capable of preventing the passage of fire to the end of the first half hour of a standard fire test.
- Hogging - The deviation of the keel from the horizontal when the keel is concave downward, ie the upper decks are in tension and the keel is in compression. **(Figure 28)**
- Hove-to - Due to the stress of the weather a vessel is manoeuvred so as to ride out the storm in the most comfortable position. This is usually achieved by heading into the sea and swell at very slow speed.
- Mullion - A vertical support in a window frame.
- Yaw - The unavoidable oscillation of the ship's head either side of the course being steered or when at anchor, due to wind and waves.

## SYNOPSIS

At 1410 UTC on 28 September 2000, the passenger cruise ship *Oriana* was on passage from New York to Southampton at a speed of about 19.5 knots when she was struck by a large wave amidships on her port side. As a result three cabin windows on deck 5, and three cabin windows on deck 6 were breached, injuring the occupants and causing extensive damage to the cabins and fittings. Storm covers had been fitted to the damaged windows on deck 5 but these were also breached.

The ship was experiencing storm force conditions and very high seas. Although the design of the windows met the strength requirements of BSMA 25, the UK standard for ships' windows, examination of the damaged windows and the remaining windows on the affected decks revealed the presence of numerous defects. The strength of the windows was significantly reduced by these defects, making them vulnerable to wave damage. Although the exact sources of the defects cannot be determined, they are likely to have originated either during manufacture or in the shipyard during, or following, installation. It is not known if the impact of the wave exceeded the designed strength of the windows. It is believed the storm covers were breached because their mounting arrangements failed.

This report makes recommendations to the manufacturer, shipbuilder, and classification society aimed at improving their quality control procedures. Recommendations to the MCA are aimed at providing clarification on the use and strength requirements for storm covers, and ensuring that standards for ship's window design remain applicable.

## SECTION 1 - FACTUAL INFORMATION

### 1.1 PARTICULARS OF ORIANA AND ACCIDENT

|                          |   |
|--------------------------|---|
| <b>Vessel details</b>    | <i>Oriana</i>   |
| Registered owner         | : P&O Cruises Limited<br>(now P&O Princess Cruises International Limited)   |
| Port of registry         | : London  |
| Flag                     | : UK  |
| Type                     | : Passenger Cruise Ship   |
| Built                    | : Meyer Werft Shipbuilders, Papenberg,<br>Germany 1995  |
| Classification society   | : Lloyd's   |
| Construction             | : Steel   |
| Length overall           | : 225.34 metres (between perpendiculars)  |
| Gross tonnage            | : 69,153  |
| Engine power and/or type | : Centre - 23850kW<br>Wing -15900kW   |
| Service speed            | : 24 knots  |
| Other relevant info      | : Bow and stern thrusters, 2 controllable pitch<br>propellers   |
| <b>Accident details</b>  |   |
| Time and date            | : 1410 UTC on 28 September 2000   |
| Location of incident     | : 49°15N, 022°50W, 570 miles west-south-west<br>of Cork, Eire   |
| Persons on board         | : Crew: 783   |
| Passengers               | : 1524  |
| Injuries/fatalities      | : One crew and six passengers suffered cuts and<br>bruises, some passengers suffered from shock<br>Damage : Six windows on the port side were<br>breached. Water ingress caused substantial damage<br>to the six passenger cabins affected. Lesser damage<br>was caused to adjacent cabins, corridors and<br>stairways. |



Unless specified, times are UTC. All courses are true. The decks on *Oriana* are both numbered and named. Throughout this report 'E' refers to *Ellora* and 'F' refers to *Formosa* decks. A deck layout is shown at **Figure 1**. It should be noted that E deck corresponds to deck 6 and F deck to deck 5.

## 1.2 NARRATIVE

*Oriana* sailed from New York at 2007(UTC – 4 hours) on 23 September 2000, for passage to Southampton. She sailed 2 hours later than scheduled and, with an ETA off Nab Tower in the approaches to Southampton at 0400 on 30 September, her required passage speed was 21.7 knots. Her planned route to the western approaches of the English Channel is shown at **Figure 2**.

The first half of the voyage proceeded as planned but, on 27 September, a depression about 1000 miles to the north-east, which had been tracking towards Iceland and away from *Oriana*, changed direction towards the south-east and began to close. The wind freshened from the west-north-west during the day and the master made several broadcasts warning passengers of the changing weather and sea conditions. In the evening, the precautions of reducing speed from 21.5 to 19.5 knots, closing dead-lights on deck 4, fitting storm covers to the windows on the port side of deck 5, and closing the exposed areas of deck 7 were taken. The captain made a further broadcast at 2200, advising passengers to be careful when moving around the ship. By 2300 the wind reached force 9 to 10 and, although it reduced slightly overnight, by the following morning it had veered to the north-west and was again force 10.

The sea was now very rough, and a moderate to long west-north-west swell was evident. The sea and swell were directionally similar but discernible with the swell moving slightly faster than the ship. Steering 071° by autopilot to make good a course of 076°, with the sea and swell on her port quarter, *Oriana* developed a 'cork-screw' motion; she was pitching but without slamming, maximum roll was about 4° each side, and yaw averaged 3° to 4° either side of the course. Occasionally waves were seen by passengers apparently to cover the windows of some cabins on the port side of decks 5 and 6 and also those on the port side of the Peninsular restaurant, also on deck 6. Both stabilisers were in use, however, and generally the ship's motion was not violent.

Shortly before 1000 the following day, the captain made a broadcast advising passengers that, as weather conditions had not altered overnight, care should still be taken when moving about the ship. He also stated *Oriana* was about 500 miles from the centre of the depression and that, because he had reduced speed, there was a possibility the ETA in Southampton might be delayed. At 1000, course was adjusted to 077°.

At 1320, the captain made a further broadcast advising elderly passengers not to go to the conservatory on deck 12. He also advised that access to the exposed areas of deck 8, along with decks 13 and 14, was restricted because of the weather.

At about 1410, a large wave struck amidships on the port side, breaching three windows fitted with storm covers on deck 5, and three windows without storm covers on deck 6. Six passengers and one crew, who were in the cabins at the time, were injured, either by flying glass or by being knocked over by the force of the water. On escaping from his cabin, one passenger deliberately activated a fire alarm in the corridor which sounded on the bridge and indicated a fire in the vicinity of cabin F178. Immediately the coxswain left the bridge to investigate. When he arrived at the scene, he contacted the OOW promptly via hand-held VHF radio, and requested the assistance of the ship's assessment party. The OOW was also notified by reception that water was running between decks 5 and 6.

At 1412, a broadcast was made directing the assessment party to proceed to cabin F178 on deck 5. The assessment party established the nature of the damage quickly and informed the captain, who reduced speed immediately and made a warning broadcast which included:

*I have sustained some broken windows on deck 5 and 6 and I'm going to turn the ship around into the wind to ease the stress. I would like everybody onboard who is not taking part in dealing with the situation to please sit down on the deck, while I turn the ship across the sea....*

He then turned the ship into sea to a course of 310° at between 3 to 5 knots.

To put the ship's company at a high state of readiness until a thorough assessment of the damage had been completed, the crew-alert signal was sounded at 1428. This was followed by a broadcast explaining the meaning of the signal and advising passengers they were not required to take any action.

By 1458, the extent of the damage had been determined and the captain decided to relax from crew alert but to remain hove-to until temporary repairs were complete. To keep the passengers and crew appraised he made a broadcast which included the following:

*The ship's company are about to be piped down from their crew alert, with the exception of those who are carrying out their duties with the damage on the port side of F deck and E deck. For the attention of passengers we are going to have to carry out some rather lengthy repairs including welding some brackets to the ship's side which will take some time. I intend for the immediate future to remain on this heading with the ship going into wind as this will be the least problematical heading and motion of the ship for those carrying out the repairs at the moment..... the ship is going to remain moving like this, ie pitching slightly for some time whilst we carry out repairs. You may again start to move around the ship but please be aware that there is some pitching and I would like you to be extremely careful in the way you walk around and be alert that at some stage in the future we will be turning the ship through the wind again, at which time I will give you plenty of notice....*

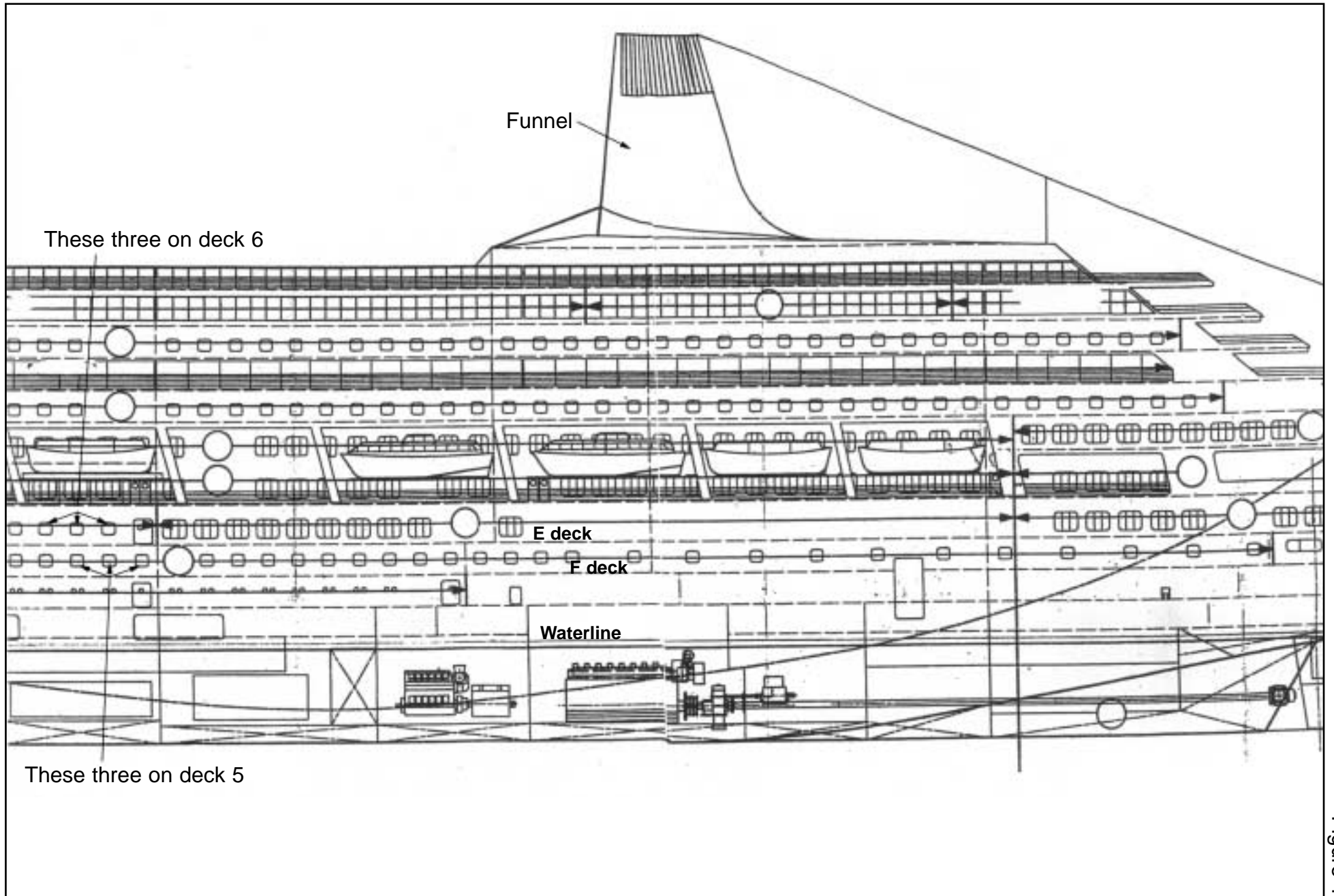
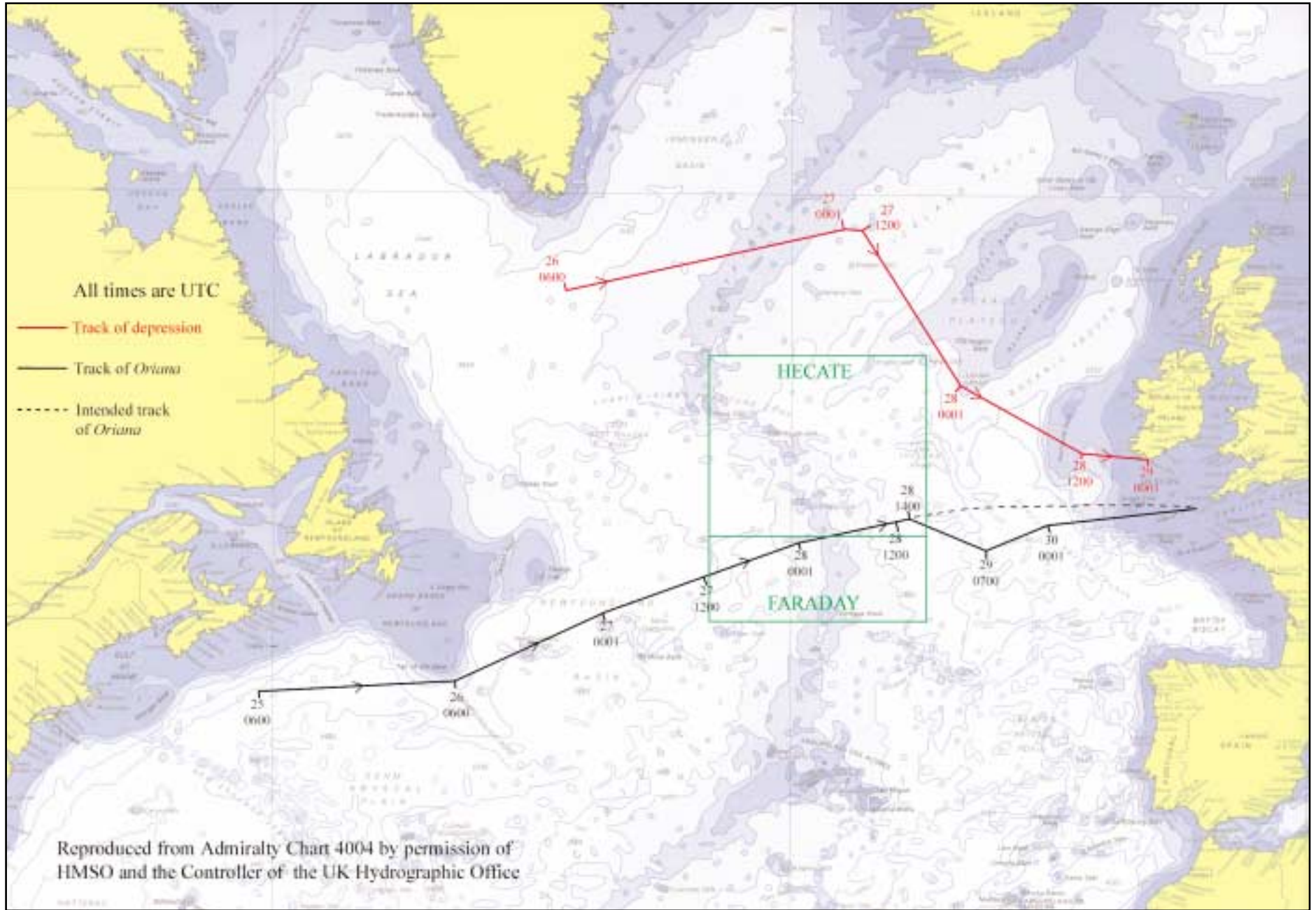

Figure 1



Extract from BA Chart 4004 showing the tracks of *Oriana* and the depression

To minimise deck movement during the window repair, *Oriana* remained hove-to. Repairs were completed at 1745, and at 1800 the captain made a broadcast which included:

*I am pleased to tell you that our repairs have now been completed and that I intend getting under way again at 6.15 this evening. At that time, I will be making a turn to starboard and increasing speed to about 15 knots and extending our stabilisers which I have had to house since we have come into sea. I am going to try to find a heading where the ship rides as comfortably as possible at around 15 or 16 knots. I would be very grateful if you would all be sitting down. The manoeuvre should take about 5 to 10 minutes to get us up to our speed and extend the stabilisers. During that period there may well be some rolling and pitching of the ship as we make the turn.*

At 1815, the ship altered course to 135° and increased speed to 16 knots. On this 'down-sea' course the ship's motion was less than it had been for the previous 36 hours. The ship remained on this course until resuming an east-north-easterly heading the following morning. The vessel arrived at Southampton on 1 October 2000.

### **1.3 INJURIES TO PERSONNEL AND DAMAGE**

#### **1.3.1 Injuries caused by the ship's movement**

On 28 September, the ship's movement caused injuries to three passengers. All occurred in the conservatory restaurant on deck 12. At 1045, an 80 year-old passenger fell off her chair, and a 66 year-old passenger struck a table edge when the ship lurched during breakfast. At 1300, a 69 year-old passenger also fell off her chair in similar circumstances.

#### **1.3.2 Injuries caused by the window breach**

Seven passengers and one crew were in the affected cabins at the time the wave struck. Only one of these escaped injury. The others suffered cuts and bruises after being knocked over by the force of the water, or when hit by flying glass. A passenger in an adjacent cabin also suffered from shock, when water poured on to her bed from the deckhead.



### 1.3.3 Damage caused by the window breach

The ingress of seawater caused substantial damage: bulkhead panels were distorted or dislodged (**Figure 3**), ceiling panels were bent with many falling into the cabins (**Figure 4**), and bathroom modules were badly damaged (**Figure 5**). The bulkhead and ceiling panels, and the bathroom modules were of a lightweight construction. Initially, the seawater was retained inside the cabins and, in some cases, the level was nearly up to the windowsill. This caused several of the passengers to have difficulty in opening their cabin doors, and escaping into the corridor because the cabin doors opened inwards. However, because the corridor bulkheads were not watertight, the water slowly drained from the cabins and flowed along the corridors and down the stairway enclosure and integral lift shafts near the damaged cabins. Although some floodwater drained to the bilges and was pumped overboard, most of it either soaked into the carpets or was mopped up by the crew.

Figure 3



Photograph of distorted bulkhead

Figure 4



Photograph of damaged ceiling

Figure 5



Photograph of damaged bathroom module

## 1.4 ONBOARD WEATHER MONITORING

### 1.4.1 Sources of meteorological information

During the passage, several sources of weather information for the North Atlantic were available and utilised. In particular, the captain relied on Meteo France synoptic information, along with forecasts and storm warnings for specified areas, including Faraday (**Figure 2**), US NWS High Seas Warnings for the area 31° to 67° north, out to 35° west, MO surface analyses, prognoses, significant wave height information, and FWOC surface analyses. Tailored weather forecasts based on the ship's planned track and passage speed were provided by Bonvoyage. However, as the latest Bonvoyage forecast received for the 28 September was based on an analysis from 25 September, the captain placed more confidence in the accuracy of weather information available from alternative sources. Investigations by P&O indicated that satellite-tracking difficulties caused by the prevailing weather conditions was the most likely reason for the non-receipt of more current Bonvoyage forecasts on board. The information provided by Bonvoyage was also self-assessing; no routing advice was provided. P&O had given consideration to using a weather service incorporating routing information, and had decided against it.

#### 1.4.2 Monitoring of the depression

On sailing from New York, the captain was aware of the synoptic situation in the North Atlantic, and was paying particular attention to the progress of a low pressure system, ex-Hurricane Helen, which had been downgraded to a depression. This depression initially moved north-east along the eastern seaboard until merging with another weather system to the east of Newfoundland on 25 September. Although deepening, this depression continued to track north-east towards Iceland and away from the ship's intended track. On 26 September, however, the following was received from Meteo France:

*Synopsis, Tuesday 26 at 00 UTC:...Low 983 280 NM south of Cape Farewell moving Northeast and deepening, expected 971 59N35W by 27/00UTC, then moving east-southeast, expected 974 59N29W by 27/12UTC.*

Aware that the depression had, or was about to, change direction to the south-east towards the ship's planned track, the captain ordered its actual and predicted positions to be plotted on chart BA 4011, a widely used chart of the North Atlantic. The positions plotted were taken from Meteo France forecasts at 0900 and 2100 daily. The path of the depression as plotted by *Oriana*, based on data supplied by Meteo France, is shown at **Figure 2**. Additionally, the ship's position was plotted on surface analyses and prognoses issued by the MO. Based on this information, the captain assessed that by reducing speed to 19.5 knots on the evening of 27 September, the ship would remain sufficiently clear of the depression to avoid the worst of the storm force conditions. The MO surface analysis for 1200 on 27 and 28 September, with the ship's position marked, is shown at **Figures 6 and 7**.

#### 1.4.3 Forecast areas

*Oriana* entered the Faraday forecast area on the afternoon of 27 September and, although leaving the area the following morning, Faraday remained the nearest forecast area for which the ship was receiving detailed forecasts. Relevant extracts of Meteo France area forecasts for Faraday received by the ship in English were:

27 September at 0900 (valid until 1200 on 28 September)

*Westerly 5 to 7 from south to north, veering soon Northwest, while increasing 7 to 9 in east.....Rough or very rough, becoming high, locally very high in east later.*

*Outlook for next 24 hours: Gradual improvement in FARADAY, ROMEO and CHARCOT. Gale or severe gale in Bay of Biscay with threat of storm westerly wind and sea becoming high with northwesterly swell 5 or 6 m.*



27 September at 2100 (valid until 0000 on 29 September)

*Northwest 4 to 6, locally west or northwest 7 to 9 in east, becoming variable 3 to 5 in west soon. Rough or very rough, locally high in east, becoming very high in east.*

*Outlook for next 24 hours: Gradual improvement in northern areas.*

28 September at 0900 (valid until 1200 on 29 September)

*In east: Northwest 7 or 8, decreasing soon 4 to 6, then becoming variable 3 or 4.....Rough or very rough, locally high in east at first..*

*Outlook for next 24 hours: Gradual improvement in all areas, then threat of southwest gale in FARADAY at the end.*

At the time of the wave damage, *Oriana* was about 45 miles north of Faraday in forecast area Hecate (**Figure 2**). Forecasts for Hecate were provided in French via voice radio by RFI and were not monitored onboard. RFI broadcast the following forecasts for Hecate over the same period (translated):

27 September (valid until 1200 on 28 September)

*Sector west 7 to 10 from south to north changing direction during the night to north-west 8 to 10 moderating at the end of the period 5 to 8 from the west towards the east. Heavy to very heavy seas lessening at the end of the period to the west. Squalls with severe gusts.*

28 September (valid until 1200 on 29 September)

*North-west 6 to 8 moderating 4 to 6 during the night turning south 4 to 5 to the west at the end of the period. Very strong to heavy sea lessening to the west. Showers followed by rain in the west at the end of the period.*

#### 1.4.4 Meteorological observations

Entries in the deck log show that from 0100 on 27 September to 1400 on 28 September, barometric pressure fell steadily from 1022.7mb to 1008.3mb and that wind veered and increased from west-north-west force 6 to north-west force 10.

#### 1.4.5 Meteorological glossary

Definitions of relevant sea and swell heights, and wind strengths are at the Appendix.

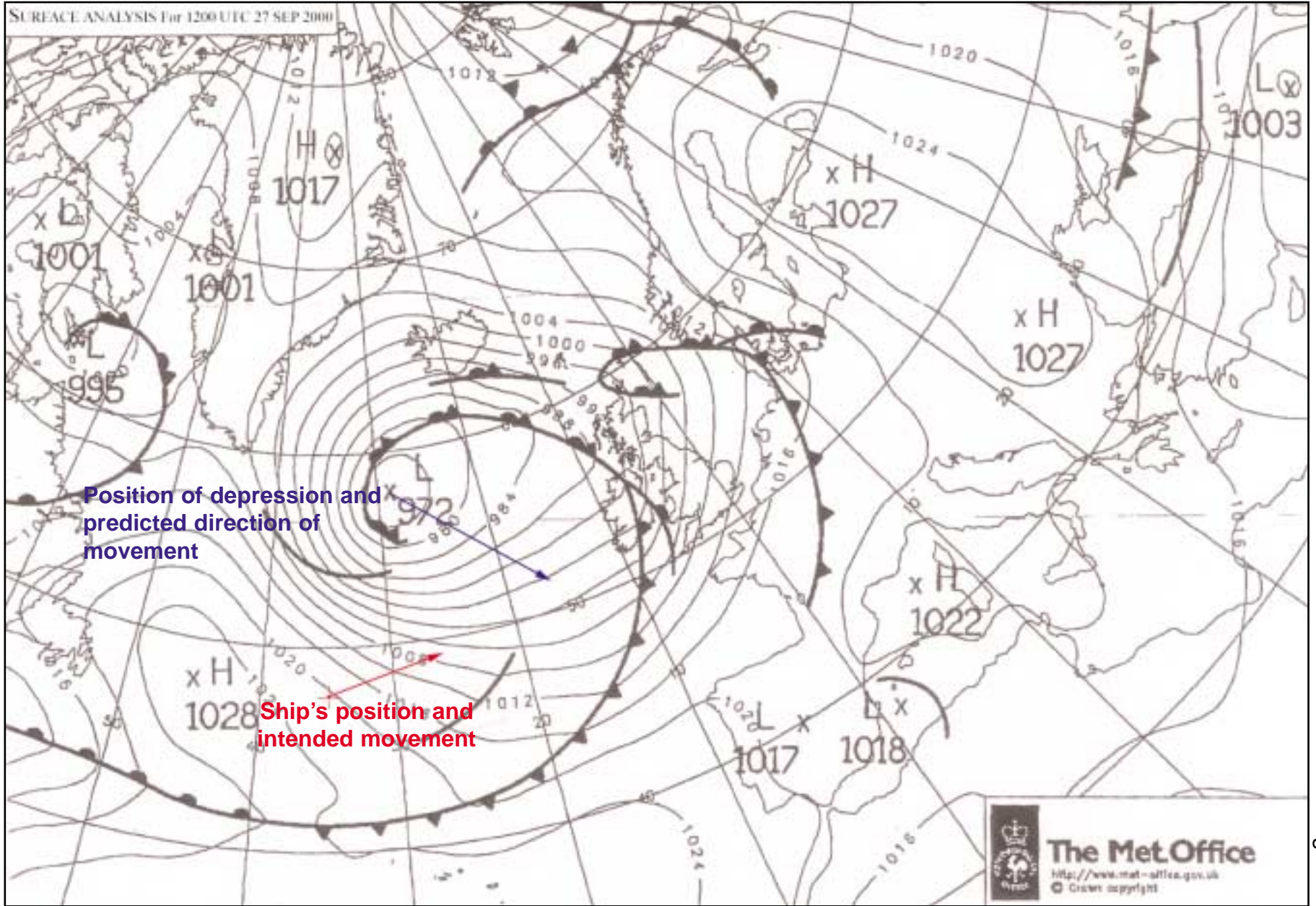

Figure 6



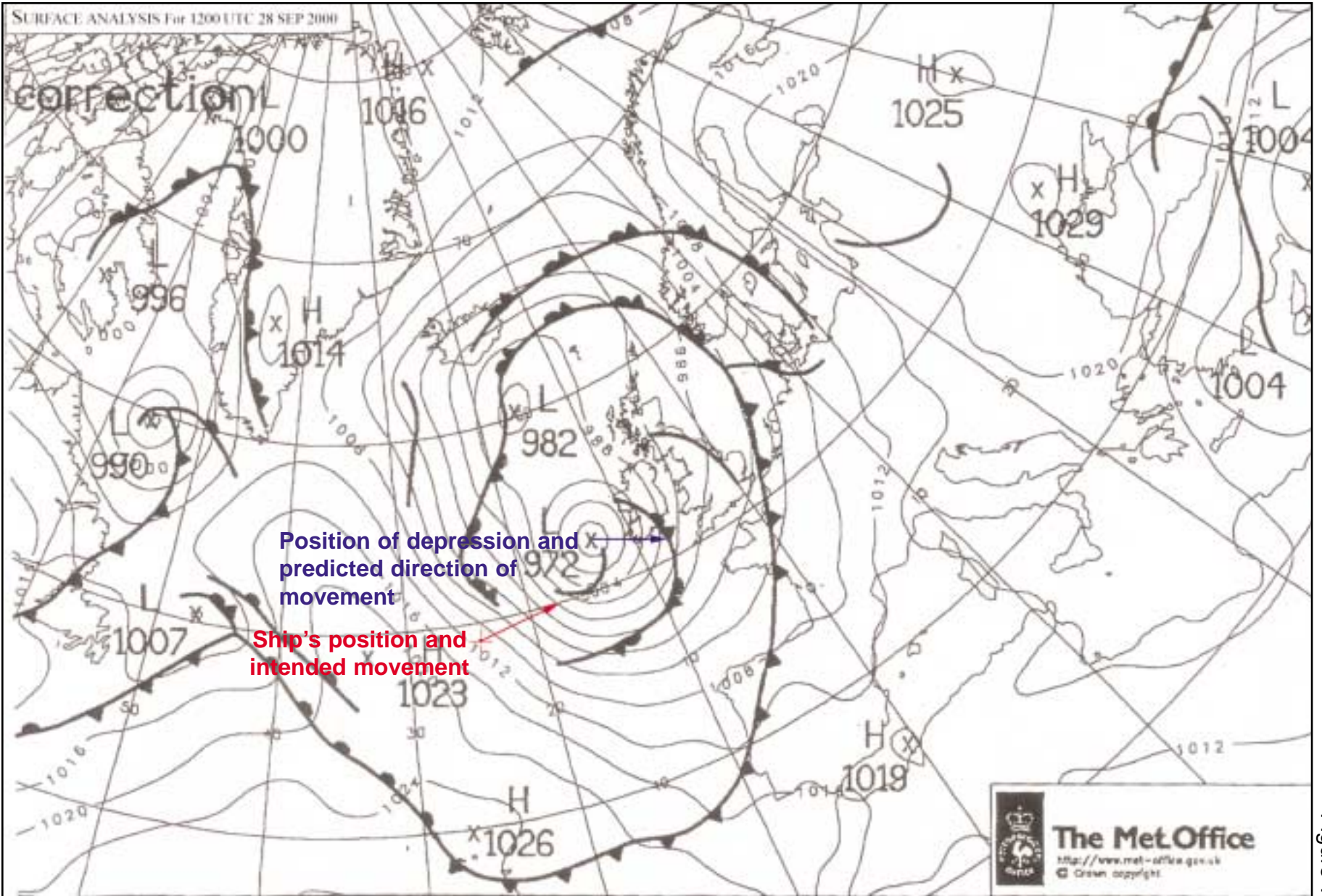

Figure 7

## 1.5 STORM WARNINGS

In addition to the information available on the North Atlantic surface analyses and prognoses charts, guidance on distances from the depression's centre, in which storm force winds were expected, was issued by NWS and received by the ship as follows:

At 2000 on 26 September (valid until 1800 on 27 September)

*Winds 40 to 50 kt, seas 19 to 25ft within 300nm W and S quadrants. Also winds 25 to 35 kt, seas 10 to 18 ft within 900nm S and 600nm E and 360nm W quadrants and 180nm N. Forecast storm well E of area.*

At 1630 on 27 September (valid until 0000 on 29 September)

*Winds 35 to 55 kt, sea 20 to 30 ft within 480nm over the SW semi-circle...winds 25 to 35 kt seas 12 to 22 ft elsewhere within 780nm of the semi-circle.*

At 2230 on 27 September (valid until 0600 on 29 September)

*Winds 35 to 55 kt seas 20 to 30 ft within 540nm over the SW semi-circle...winds 25 to 35 kt seas 12 to 22 ft elsewhere within 720nm over the SW semi-circle.*

## 1.6 SHIP'S MOTION AND WAVE HEIGHTS

### 1.6.1 Deck log entries

27 September:

- 0800 - Rolling gently 1° - 4°. Short/Mod NW swell, rough seas.
- 1200 - Shipping light spray forward. Pitching in rough seas. Heavy swell.
- 1600 - Rolling mod in rough seas. Heavy swell.
- 2000 - Pitching/yawing. Moderately to Long/High WNW swell and rough seas.
- 0000 - Pitching/rolling moderately, heavily at times to a long, high WNW swell and rough seas.

28 September:

- 0400 - Rolling and pitching moderately in very rough seas. Heavy swell.
- 0800 - Pitching and yawing moderately to long/high WNW swell. Very rough seas.
- 1200 - Shipping light spray forward. Pitching and yawing in long high swell. Very rough.

### 1.6.2 Individual assessments

The captain, who had served on cruise vessels for most of his sea-going career, often in sea and weather conditions broadly similar to those encountered by *Oriana* on this occasion, estimated the sea to be from the port quarter and the wave height to be about 6 to 7m. He also considered the ship motion was not violent, but that she was moving easily in rough seas.

Just before the accident, the captain had lunch in the officers' mess on deck 5 and then made his way up through the ship to the bridge. During this period he was able to observe the sea conditions from various levels in the ship, and was satisfied that waves were not breaking over the promenade deck.

The OOW at the time of the incident estimated the swell height to have been about 5m and considered the ship was riding well in a cork-screw motion. Although the occasional larger wave was seen, the height of the waves did not give cause for concern.

Reports from passengers reflected varying degrees of concern regarding the ship's movement. Many were able to walk around the vessel with ease, while others had difficulty in maintaining their balance. Some reports, however, indicated that the ship's motion was sufficient to cause crockery to slide from the tables in the restaurant and for products, such as perfumes and clothes in the shops, to be dislodged from their racks. Of those passengers interviewed, a number were worried about the height of the waves, particularly when they appeared to cover the windows on decks 5 and 6 on the port side.

### 1.6.3 Video evidence

Video recordings taken by passengers on 27 September, and at about midday on 28 September show that the sea conditions worsened during this period. One of the latter recordings, taken from deck 7 on the port side at a height of about 13m above the static waterline, from which **Figures 8, 9, 10 and 11** were taken, confirms that the sea and swell were generally from the port quarter.

**Figure 9** shows that some of the waves were breaking and **Figure 10** shows a plume of spray at deck 7, which probably resulted from a wave impacting against the port side. Although it is not possible to determine accurately the height of the waves from this video, and there is no evidence to suggest that waves were breaking over deck 7, **Figure 11** possibly indicates that some waves could have been as high as deck 7.

It is acknowledged, however, that the images shown were taken from different positions within the ship, possibly using different focal lengths, and at various stages of the ship's movement, and although providing a general guide, they cannot be used as an accurate measure of the conditions prevailing at the time.

Figure 8



Photograph of waves from the port quarter

Figure 9



Photograph of a wave breaking

Figure 10



Photograph of a plume of spray at deck 7 probably resulting from a wave impacting on the port side

Figure 11



Photograph of wave of a similar height to deck 7

#### 1.6.4 Voyage Data Recorder

Analysis of the voyage data recorder indicates that the vessel was steering a course of 071° to make good a course of 077° and that starboard helm, occasionally up to 19°, was required to maintain this course. It also showed that, although the average yaw of the vessel during 28 September was about 3° to 4° either side of the course steered, occasionally it was greater. For example, at 1256 the ship yawed from 074° to 062° over several seconds. The impact of the wave at around 1410, however, did not cause a noticeable deflection to the ship's head. No pitch or roll information was available.

#### 1.6.5 Significant wave heights

Significant wave height is defined as the average height of the highest third of the waves, and wave height is measured from crest to trough. Diagrams showing predicted significant wave heights for 0000 and 1200 on 28 September 2000, along with the ship's positions at these times, are at **Figures 12 and 13**. In a typical storm the expected height of the highest wave is usually 1.8 to 2.0 times the size of the significant wave height. There is, however, about a 1% chance of a wave 2.5 times the size of the significant wave height being encountered.

### 1.7 THE WINDOWS

#### 1.7.1 Design requirements

Windows were fitted to decks 5 and above in accordance with MCA Regulations. The requirements of BSMA 25 were met and toughened safety glass was used.

BSMA 25, first published in 1973, is the UK national standard for ship's windows with glass up to a thickness of 19mm. In most other countries, the national standard for ships' windows is based on an ISO standard which, in turn, was based on BSMA 25.

BSMA 25 required that, for the position and size of the windows fitted on decks 5 and 6 of *Oriana*, the following criteria should be met:

- a. The glazing strips should have overlapped all window edges by at least 7mm.
- b. The glass should have chamfered edges.
- c. The glass should be centralised in the frames.
- d. Windows on deck 5 should be able to withstand a static pressure head of water of 6.57m, and those on deck 6 a static pressure head of 1.5m.

There was also a requirement for windows fitted below lifeboat and liferaft launching arrangements to be fire resistant.



Figure 12

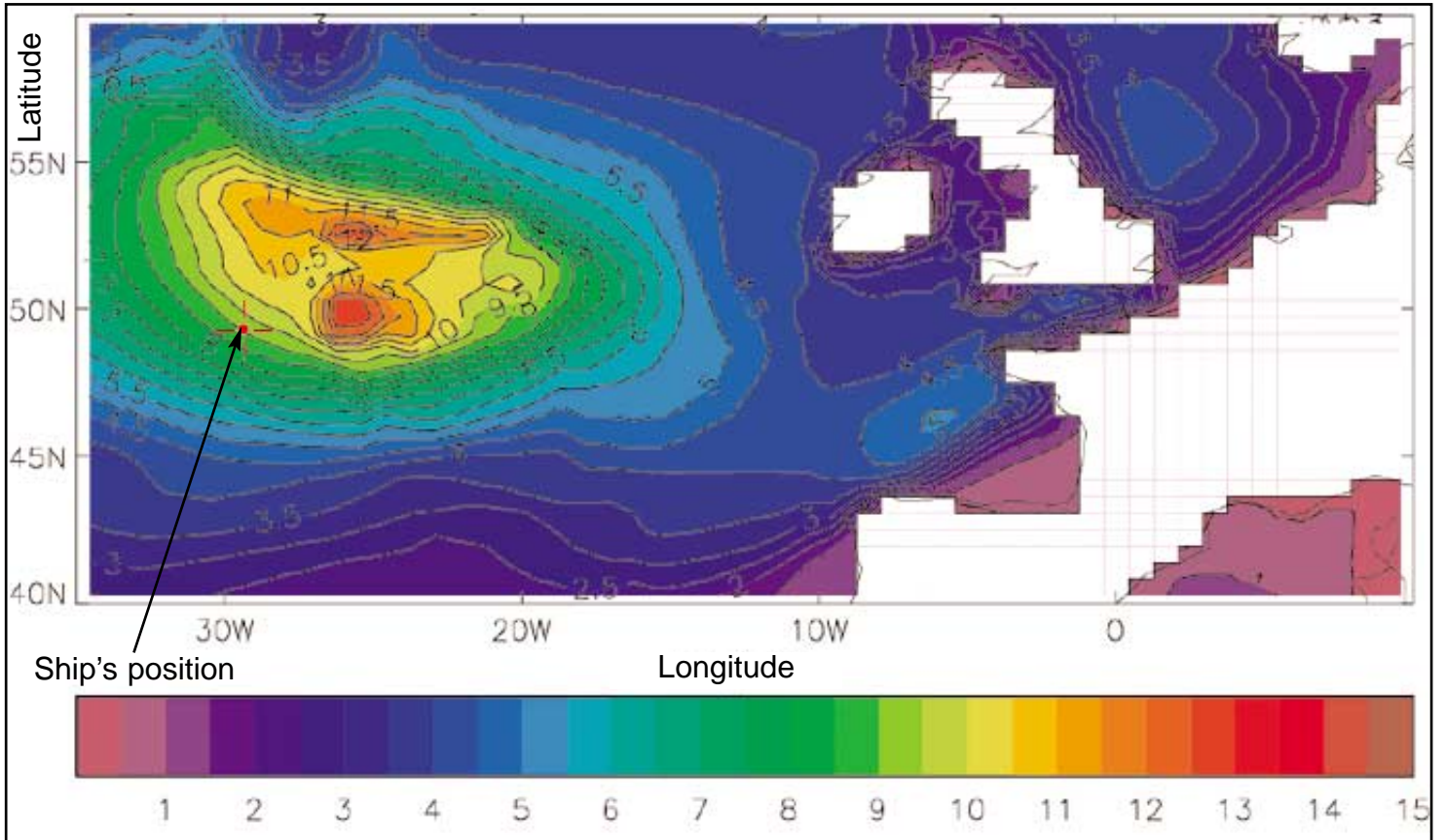

Diagram showing Significant Wave Heights for 00Z on 28 September 2000

Figure 13

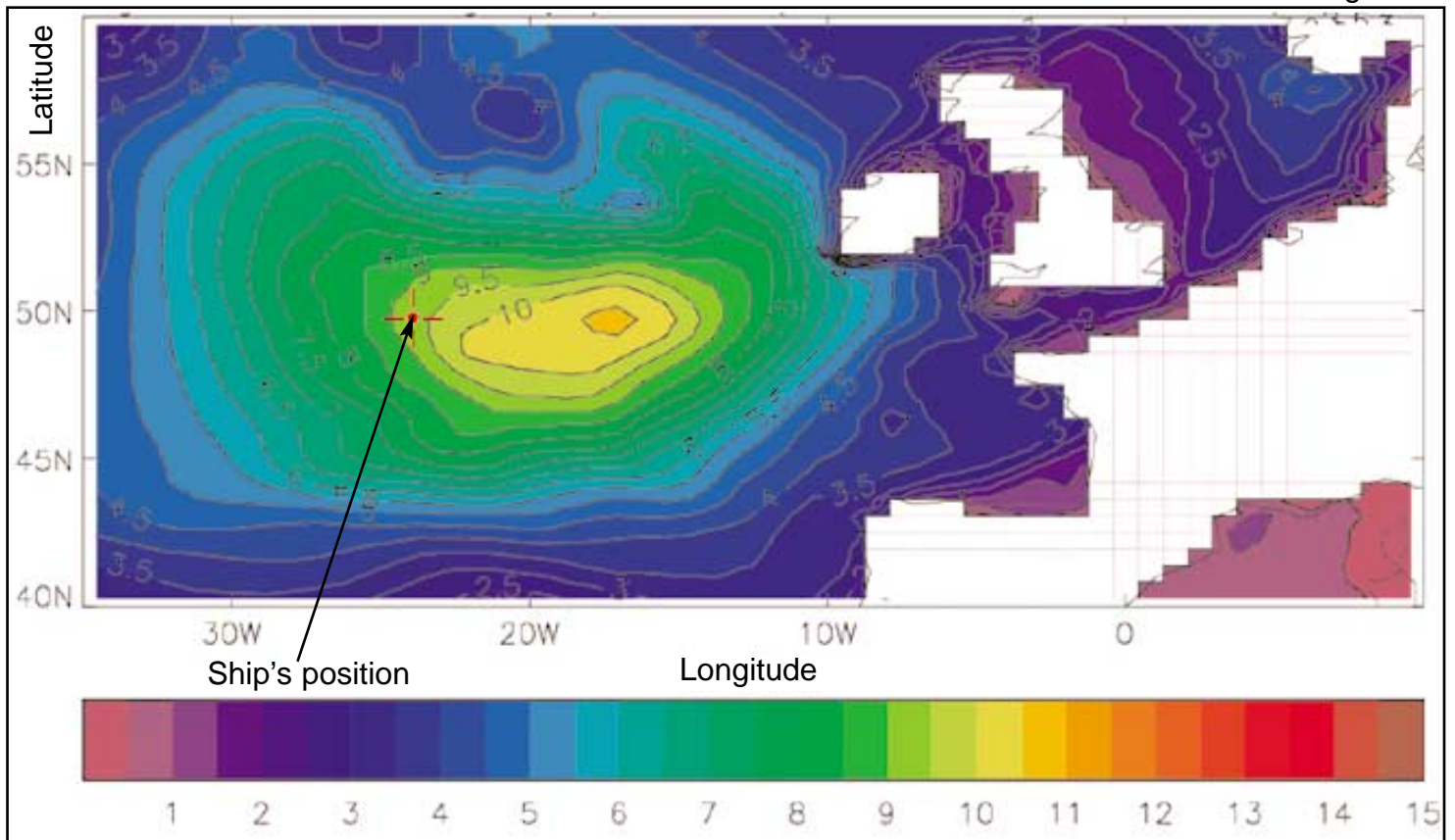

Diagram showing Significant Wave Heights for 12Z on 28 September 2000

### 1.7.2 Type approval

Type approval is the process where a product is examined by a competent body to determine its fitness for purpose. In this case, type approval for the breached windows was undertaken by the MSA, the forerunner to the MCA. A type approval certificate was issued in July 1994 after two specimens were successfully fire tested, and the strength was checked against the requirements of BSMA 25.

The two specimens, fire tested as part of the type approval, had clear heights and widths of 2000mm and 1000mm; one was fitted with 15mm monolithic glass and the other with 22mm laminated glass.

The certificate of approval stated that mullions and/or transoms should not be fitted.

### 1.7.3 Manufacture

The windows were manufactured by Het Anker in the Netherlands, using toughened safety glass supplied by Sacilese in Italy.

The damaged windows on deck 5 were Het Anker Type 507 (**Figure 14**). These windows had a clear light height and width of 1000mm and 1100mm respectively. The windows were divided in two by a 50mm wide mullion, with 'D' shaped glass panes made from 19mm, B-0 fire rated, toughened safety glass fitted on either side. They were designed to withstand a static pressure head of water of 8.83m.

The designed height and width of the openings cut in the ship's side for the windows was 1064 and 1164mm respectively. A 30mm stainless steel glazing strip was fitted on each side and this, plus an allowance of 2mm all round for welding the window frame into the opening in the ship's side plating, accounted for the difference between the clear height and width, and the size of the openings.

The glass was fixed into a recess in the steel window frame. A fire resistant gasket was fitted over the glass where it was in contact with the frame and the stainless steel glazing strip. **Figure 14** shows that the gap between the frame and the fire resistant gasket covering the edge of the glass was designed to be filled with chocks made from Promasil 850, which kept the glass central to the frame. The glazing strip, which was located on the inboard side of the window, was 30mm wide by 5mm thick and was screwed into the window frame by M6 stainless steel screws spaced 71mm apart. The glass, therefore, was secured in its frame by the force of the screws, acting on the glazing strip. The glazing strip was 50mm wide in way of the mullion.

The damaged windows on deck 6 were Het Anker Type 606 (**Figure 15**). These windows are the same as those fitted on deck 5, except that there was no mullion and the single pane was made of 15mm monolithic glass with four rounded corners. These were designed to withstand a pressure head of water of 2.77m.

By scaling the window design drawings (**Figures 14 and 15**), it is estimated that the dimensions of the glass panes fitted in both window types should have been sufficient to produce about a 13mm overlap with the glazing strip.

#### 1.7.4 Quality control

A Lloyd's Register surveyor visited the Het Anker factory on at least seven occasions during 1993 and 1994, specifically to inspect the windows being manufactured for *Oriana*. He also visited the factory on numerous other occasions for different reasons, and was able to monitor the standards of workmanship and quality control practised. *Oriana's* windows were dispatched in batches, and each window was stamped with the surveyor's own mark, after a random sample in each batch had been checked. The windows were supplied to the shipbuilder with Lloyd's Register certification based on an approximate 50% random sample inspection of 385 glass panes for 194 windows of various configurations, during manufacture and assembly. All windows were examined in the finished state.

Het Anker currently issue welding instructions with all windows dispatched from its factory (**Figure 16**), but they were unable to confirm if these or similar instructions accompanied the windows made for *Oriana*.

#### 1.7.5 Installation

Het Anker delivered the windows as assembled units. Openings were cut in the ship's side, into which the window assemblies were fitted and the frames welded to the ship's side plating. The builders, Meyer Werft, in Papenberg, Germany has no knowledge of any oversize openings having to be cut to accommodate oversize frames. The thickness of the side plating was 14mm on deck 5, and 15mm on deck 6. Meyer Werft could not confirm if the welding instructions issued by Het Anker (**Figure 16**), or similar, had been used to secure the windows in *Oriana*, but a staff member, who had worked on her during building, recalls a chain intermittent welding sequence being used to minimise distortion. On vessels currently building, Meyer Werft now use ultrasonic equipment to check the overlap of the glazing strips over the glass panes.

Following installation, some glass panes were removed, to allow electric power cables, air lines, and large items to be passed into the ship. The equipment supplying all electric power and compressed air, however, was located along her starboard side during building. It has not been possible to determine whether any glass panes from windows on the port side, including the damaged windows, were removed. All windows were hose-tested by the shipbuilder to check for leaks.

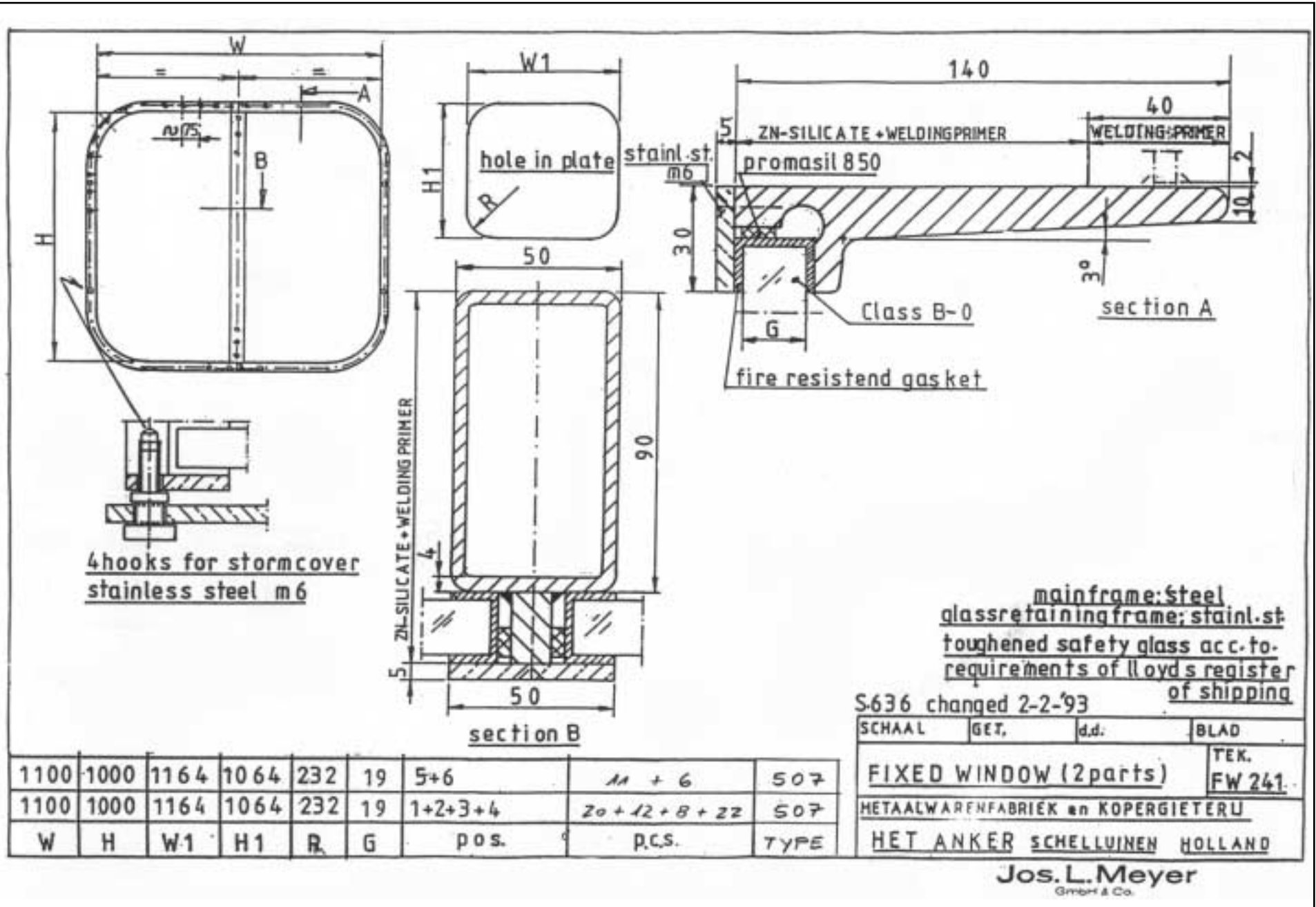

Drawing of Het Anker type 507 window

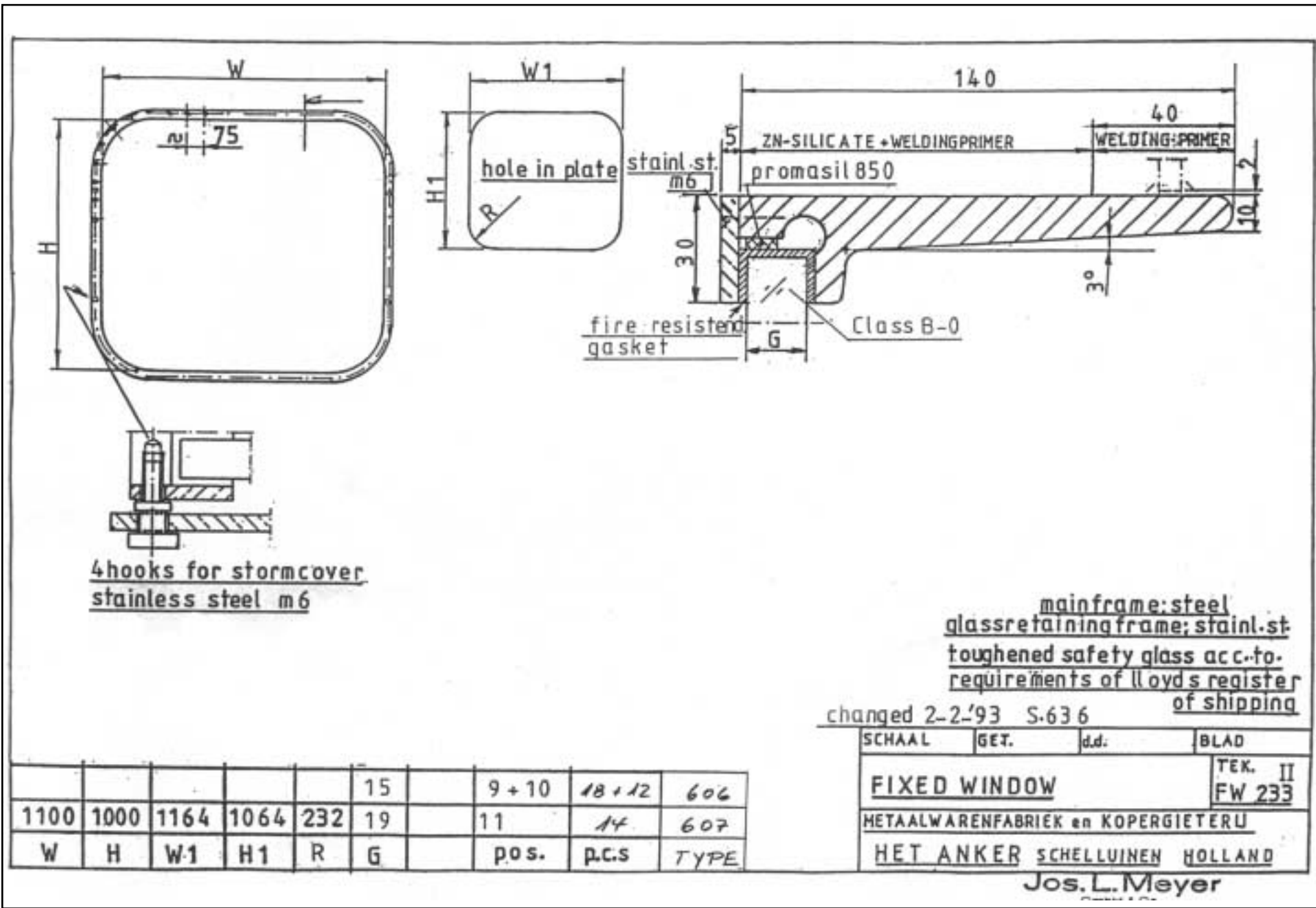

Drawing of Het Anker type 606 window

DO NOT EXCEED 80 C

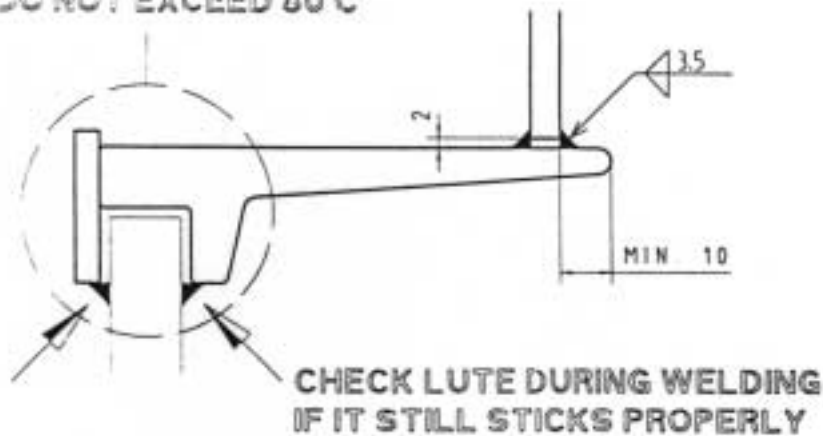

WELDING DETAIL FOR WINDOWS

NOTE:

CAREFULL ATTENTION TO WELD SIZE AND SEQUENCE, IN ORDER TO GIVE MINIMAL HEAT AND DISTORTION TO FRAME.  
THE TEMPERATURE AT THE RETAINING FRAME AND THE GASKET SHOULD NOT EXCEED 80 .  
INSPECTION OF THE FRAME AND GASKET AFTER WELDING BEFORE PROCEEDING ANY OTHER FRAME

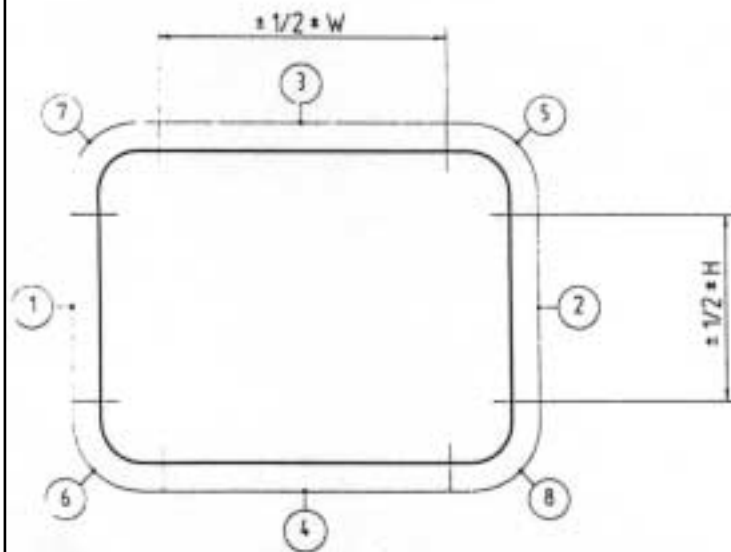

WELDING SEQUENCE FOR WINDOWS

DO NOT WELD MORE THAN 20 cm AT ONCE.  
INSPECT THE FRAME DURING WELDING PROCES  
IN ORDER TO GET MINIMAL DISTORTION OF THE FRAME

METAAL WAREN FABRIEK



"HET ANKER"

WINDOWS, PORTHOLES and DOORS  
SCHELLUNEN HOLLAND



### 1.7.6 Damage

The position of the damaged windows is shown in **Figures 1 & 17**. The cabins affected were F176, F178, F180, E172, E174 and E176, all of which were situated approximately amidships on the port side (**Figure 18**).

In cabin F180 only the aft pane was breached. In F176 and F178 all four panes were breached; three of these were found intact (**Figure 19**), of which two were found to have chipped or splintered edges. These marks appear to have been made by the glazing strip, and the marks on the edge of the glass, next to the mullion, extended further across the pane than those on the opposite vertical edge.

Following the breach, some glazing strips remained in position, although some sections were badly distorted. Also, some screws holding the glazing strip in place had sheared off, while others remained intact but were bent. As the glazing strips and associated screws were removed to properly seal the openings during the damage repairs, the extent of their damage was difficult to ascertain. There was no visible damage to the mullions.

None of the glass panes from the breached windows on deck 6 were found intact, and the occupants in the affected cabins at the time of the breach believe the glass was shattered as the wave struck.

There was no damage to rails or other deck fittings sited on deck 7 above the breached windows.

Figure 17

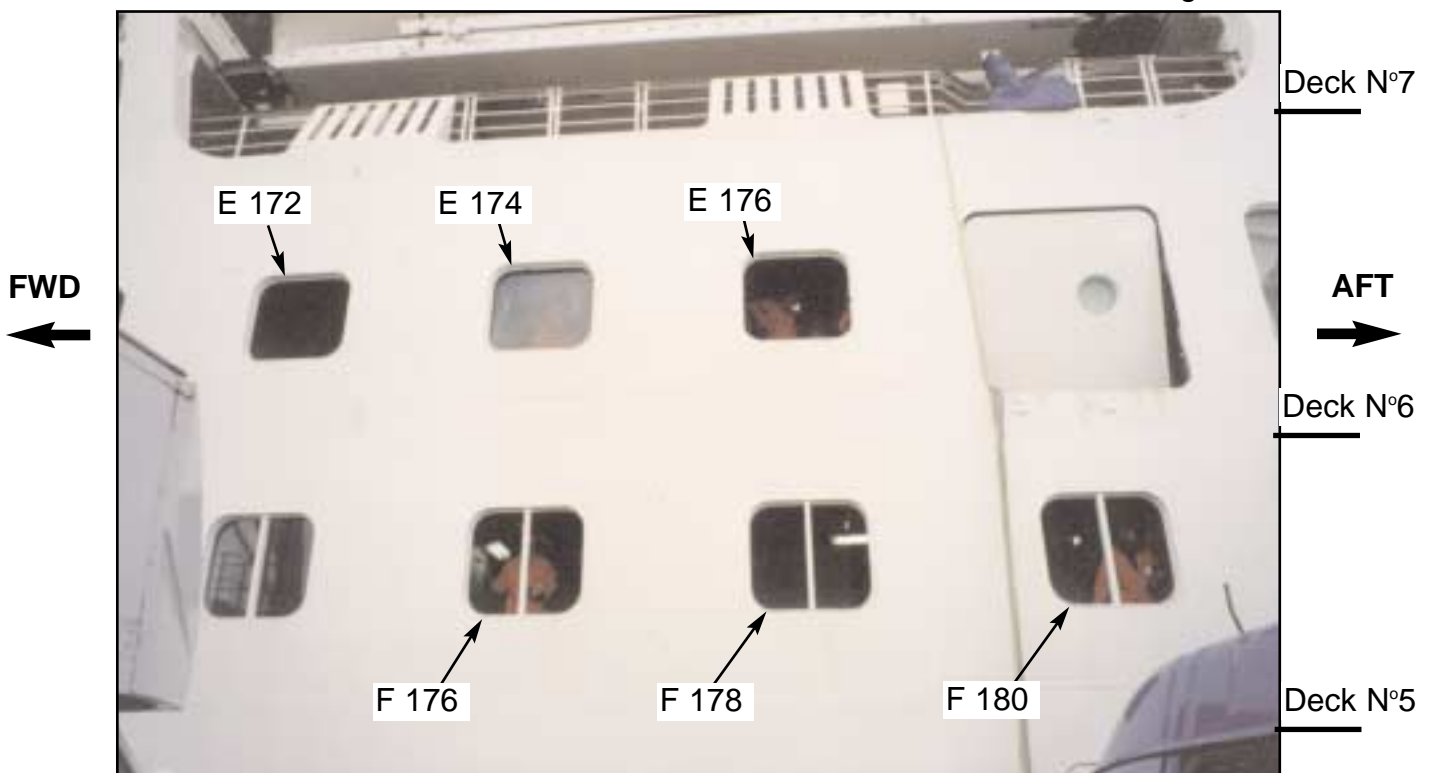

Photograph showing position of damaged windows

DECK 5

STARBOARD

← FWD

PORT

F176  
F178  
F180

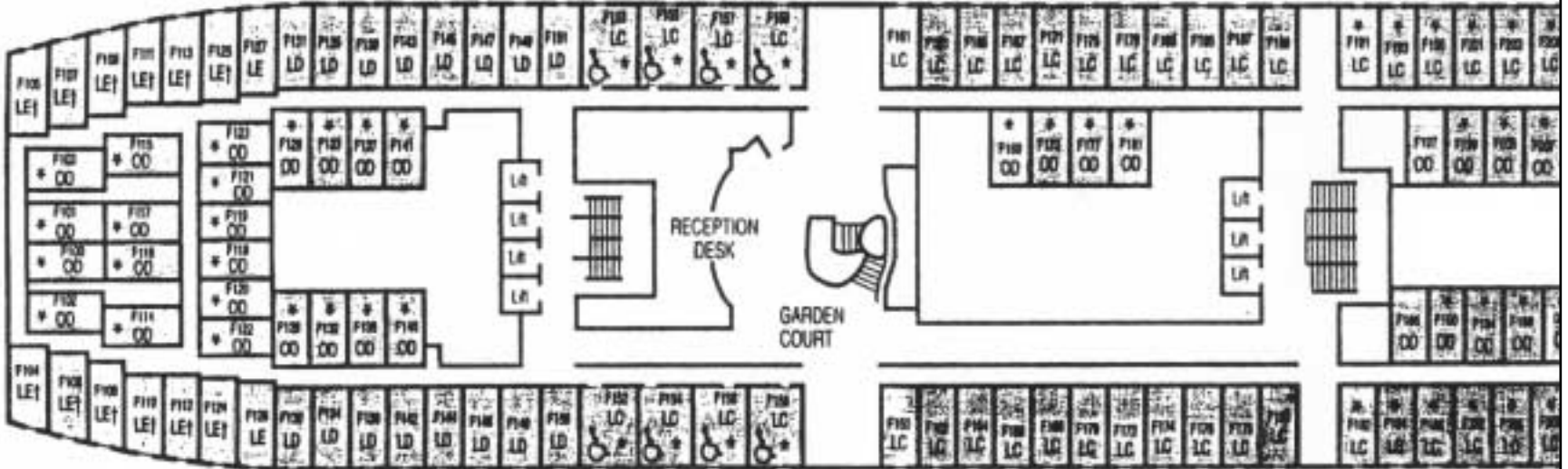

STARBOARD

DECK 6

PORT

E172  
E174  
E176

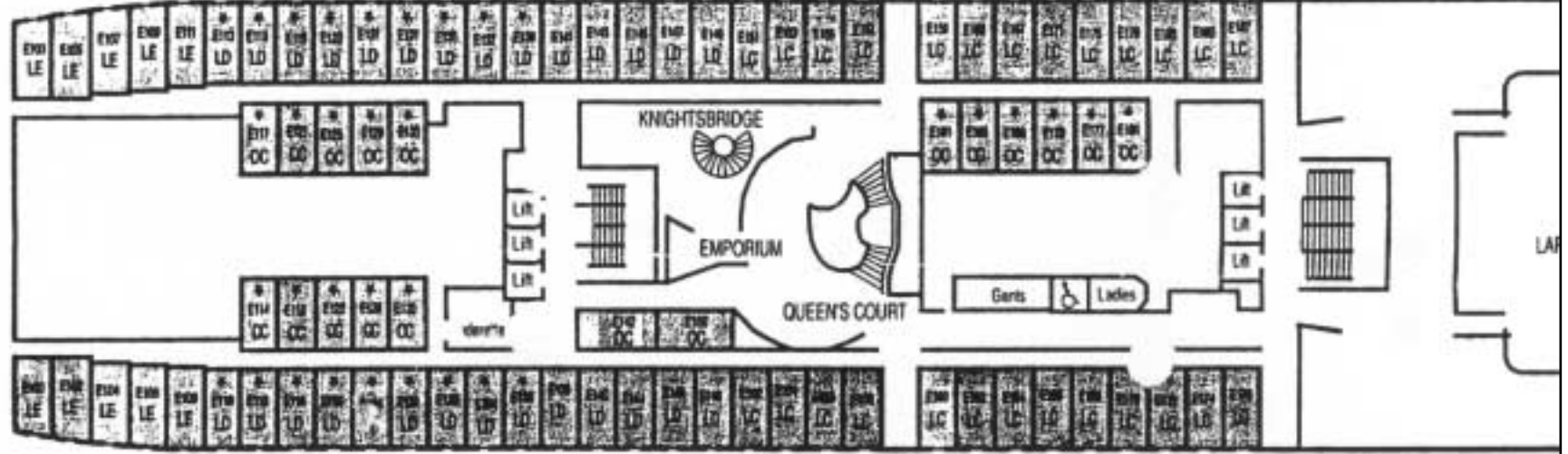

Diagram showing the positions of the damaged cabins



Figure 19



Photograph of glass pane found intact

### 1.7.7 Damage repairs

Three damage repair parties were formed. The first dealt with the damage on deck 5, the second dealt with the damage on deck 6, and the third prepared materials. The repair parties were organised by the chief technical officer who had attended an RN damage repair course. It was company policy for P&O to send all officers of his rank on this course. Another officer involved in the repairs, who had previously served in the RN, had also attended this course.

Initially, the damage repair teams fitted strong-backs which were placed in sockets cut into the fairings surrounding the windows, but it was soon evident this would not provide sufficient support. However, after discovering that the fairings were attached by screws concealed by small plastic caps, these were removed and the fairings taken down to expose the steel structure surrounding the window frames. Three horizontal strong-backs were then fitted across each opening, with the ends welded to steel stiffeners on the ship's side (**Figure 20**). The strong-backs were either square or angle steel sections obtained from the ship's stores. The windows were then blanked off by either storm covers or plywood sheets. Wooden wedges were then driven into the gap between the strong-backs and the covers, to secure the covers in place. The materials used by the repair teams were prepared in the ship's workshops.

## 1.8 WINDOW DEFECTS

### 1.8.1 Examination by P&O

As soon as practically possible after the accident, a detailed dimensional check was conducted by P&O on all windows on decks 5 and 6. Several defects were revealed to varying degrees on a large number of the windows surveyed. Among these defects were:

- a. Oversize window frames. The worst case being the damaged window in F178 cabin, which was 16mm wider and 4mm higher than designed. The remaining damaged windows were larger than designed as follows:

| Cabin | Width | Height |
|-------|-------|--------|
| F176  | 10mm  | 5mm    |
| F180  | 10mm  | 5mm    |
| E172  | 6mm   | 6mm    |
| E174  | 8mm   | 9mm    |
| E176  | 4mm   | 7mm    |

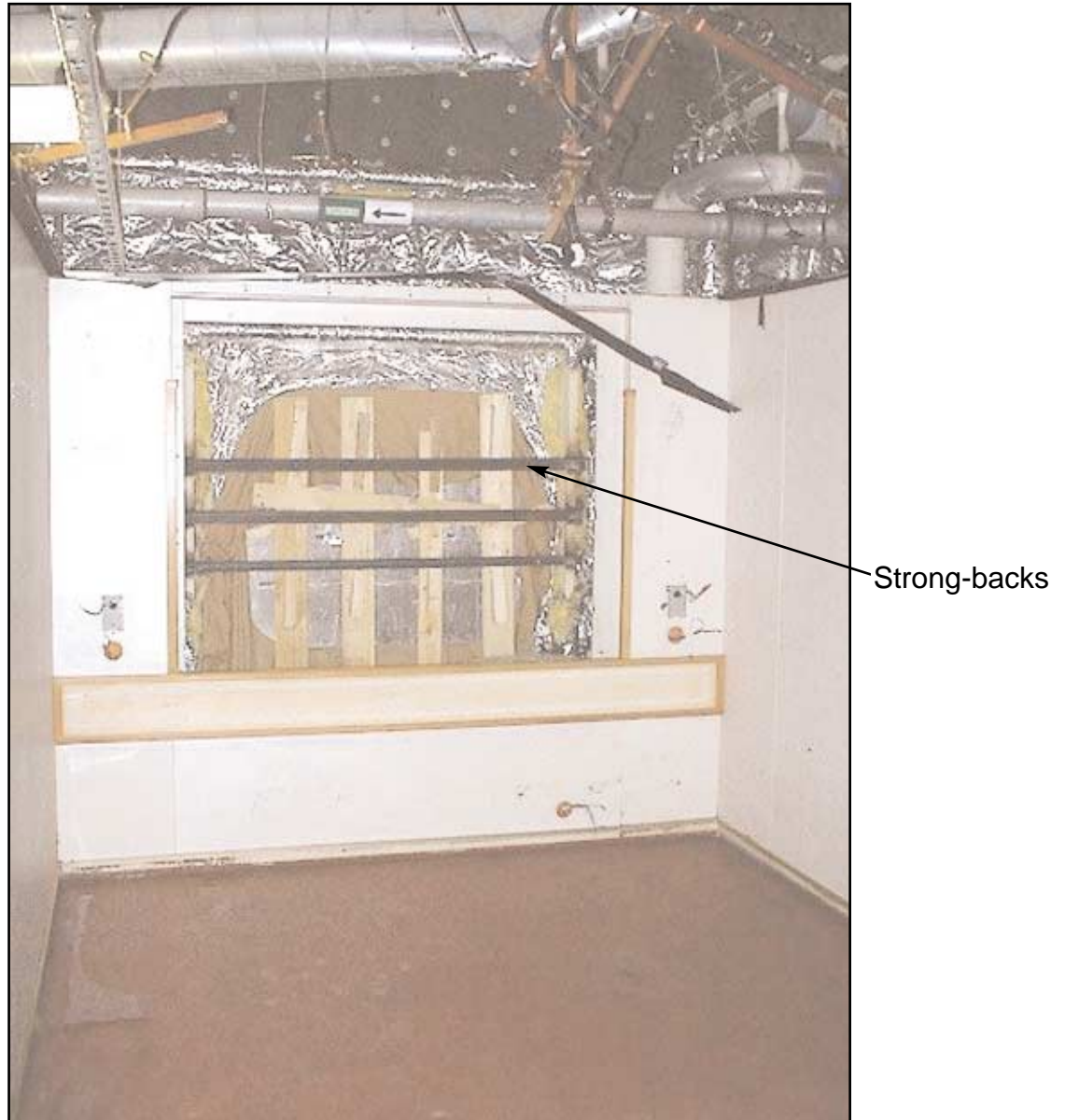

Photograph of temporary repair to a damaged window

- b. On many windows, the glazing strip overlapped the glass by less than 7mm; in some cases the overlap was as low as 2mm. It was also found that the dimensions of nearly all of the glass panes fitted would have allowed an overlap with the glazing strip of between 7 and 13mm, although many were towards the lower end.
- c. Window-panes not properly centred. This was especially prevalent in the windows with mullions where the glass was deeply recessed into the mullion, at the expense of the recess on the other vertical edge.
- d. Glass panes had a rounded edge profile.
- e. Regarding the stainless steel screws used to secure the glazing strips: some were of differing lengths; some had sheared, some had damaged threads; some threads were covered in mastic while others were not; and many of the Phillips heads were damaged.

- f. Some gaskets looked different to others, and the hardness appeared to differ. Some windows were fitted with plastic chocks and some were not. It was assumed that the chocks were made from Promasil 850.
- g. Some stainless steel glazing strips were deformed. Where the gasket was too thick for the recess, tightening the screws tended to deform the strip, leading to a gap opening up on the inner edge (**Figure 21**). Consequently, with a gap at the inner edge of the strip, the glass was not clamped properly on the frame.

After *Oriana*'s arrival in Southampton on Sunday 1 October 2000, the MAIB was unable to carry out its own extensive and detailed survey during the limited time available, because she sailed the following day on her next cruise.

Figure 21

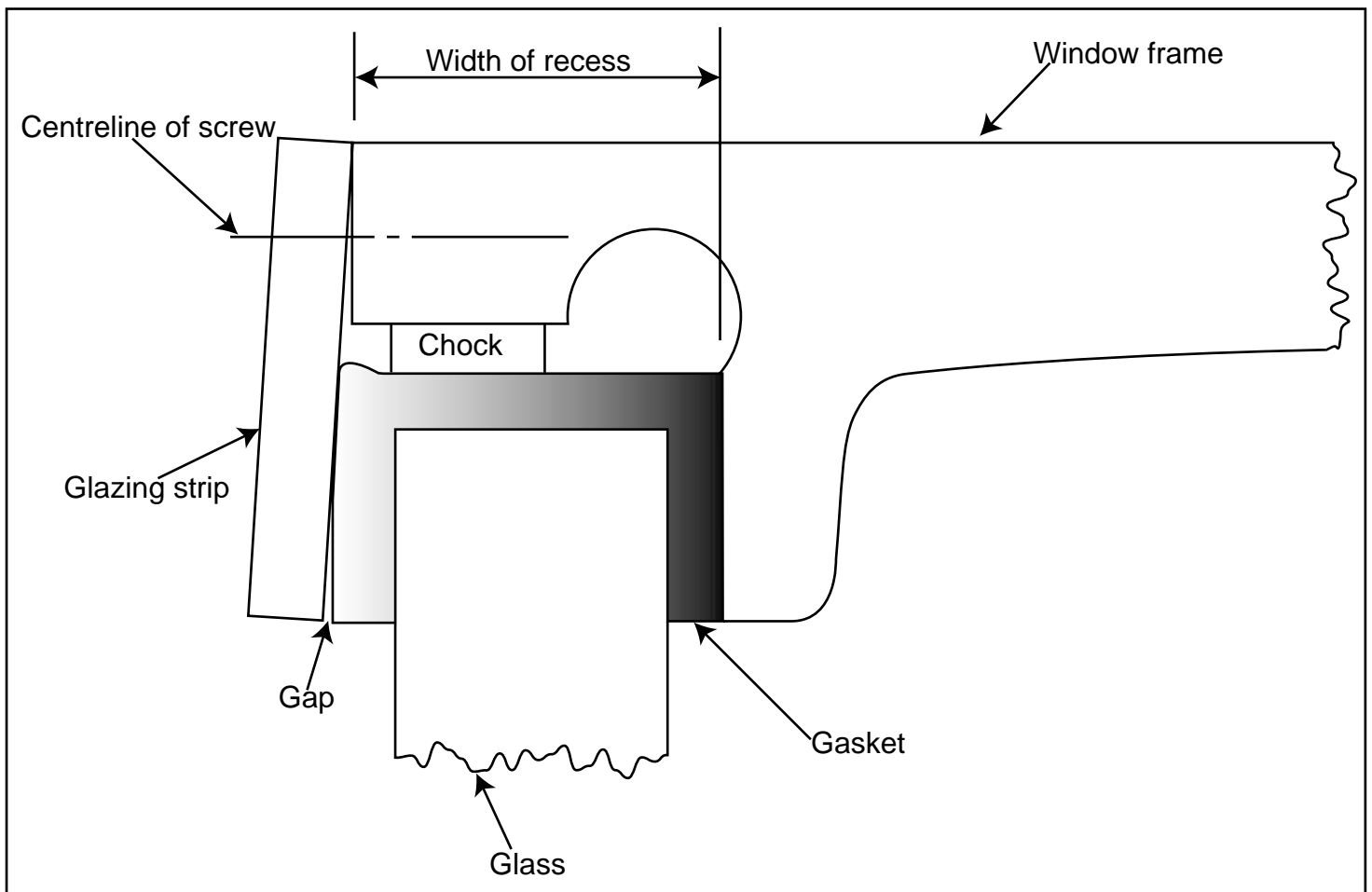

Diagram showing gap caused by poor fitting gasket

## 1.8.2 Checks and tests conducted by Het Anker

Representatives from Het Anker visited *Oriana* between 17 and 20 October 2000 and surveyed some of the windows previously inspected by P&O. As a result of this survey, Het Anker contend that the dimensions of the glass panes seen were generally larger than measured by P&O.

Het Anker also conducted a number of destructive tests following the accident, from which it formed the opinion that the windows delivered to Meyer Werft met the as-designed strength requirements, and that the wave pressure causing the damage, exceeded this strength.

## 1.9 STORM COVERS

### 1.9.1 Requirements

The requirements for storm covers or shutters are contained in the MCA's *Instructions for the Guidance of Surveyors on Passenger Ship Construction*. *Oriana* was required to carry enough covers for 50% of the windows on deck 5, and for 25% of the windows on deck 6. The covers were required to be made from 3.5mm steel or equivalent, and be *“provided with means of securing them to the frame sufficient to withstand the pressures likely to be experienced in service”*.

### 1.9.2 Securing arrangements and construction

“T” shaped lugs were screwed into the frames of both types of window on which storm covers could be slotted, to provide a barrier on the inside of the glass (**Figures 22 and 23**). The storm covers were made from 4mm thick aluminium plate, which was stiffened by two aluminium flat bars, rather than from 5mm unstiffened aluminium plate as originally designed. The shipbuilders assured the MCA at survey that these 5mm aluminium covers were of equivalent strength to 3.5mm steel plate. There is no evidence available to indicate that the MCA did not accept this assurance.

### 1.9.3 Damage

When the windows fitted with storm covers on deck 5 were breached, the storm covers were forced off their mountings by the pressure of the water. The sockets cut in the sides of the storm covers were ruptured as they were pushed off the lugs (**Figure 24**). The storm covers were also bowed.

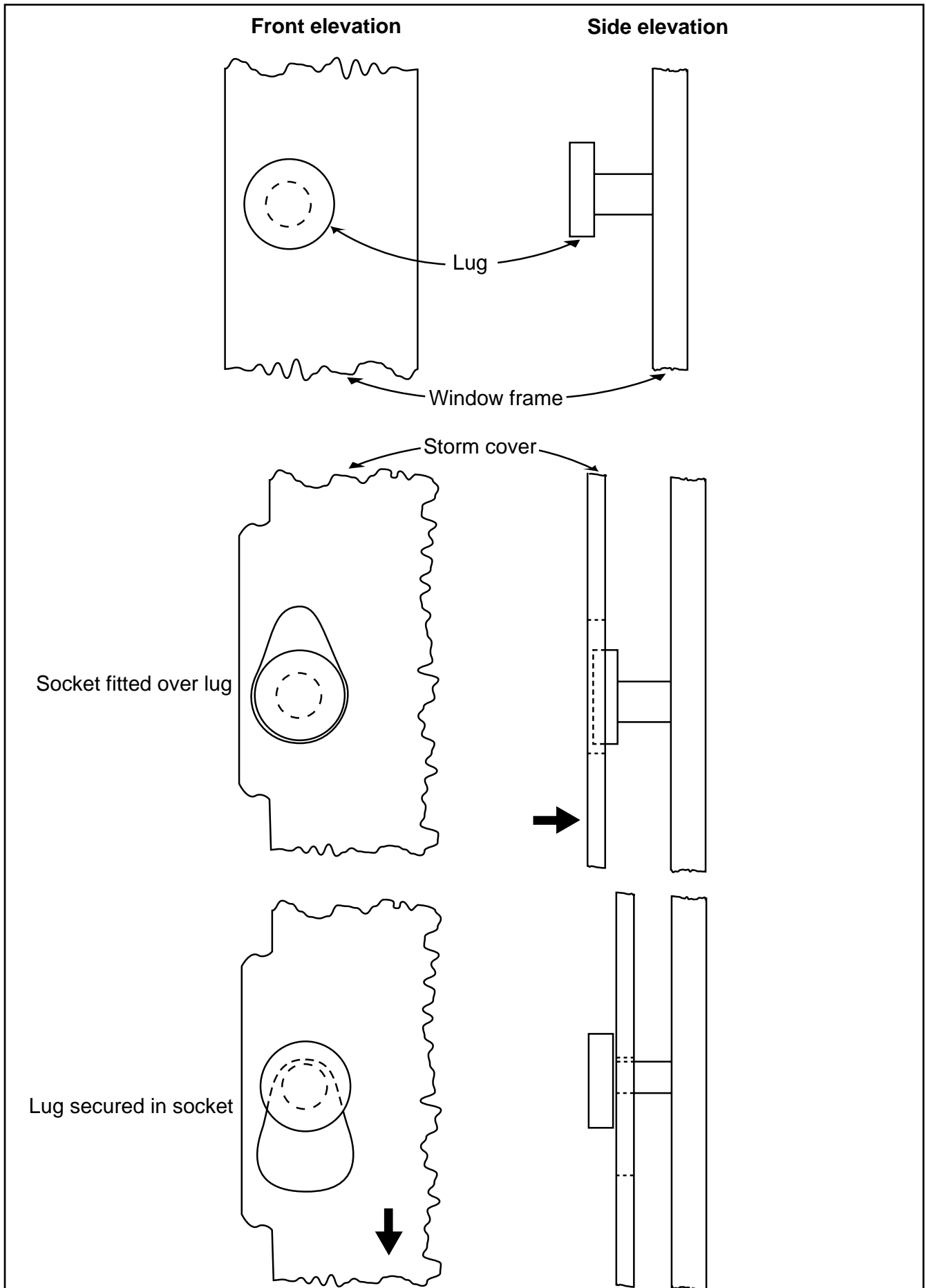

Diagram of the securing arrangement for storm covers



Photograph of storm cover in position

Figure 24



Photograph of ruptured sockets

## 1.10 VESSEL CONDITION

At the time of the accident, the centre of the damaged windows on deck 5 was about 7.3m above the static waterline, while the centre of the damaged windows on deck 6 was about 10.1m above the static waterline. The draught of the vessel at the time was 8.343m aft and 8.015m forward. The condition at this draught was checked against the stability book and it was confirmed that *Oriana* was not overloaded, ie the windows were not closer to the waterline than they should have been.

## 1.11 ACTION TAKEN REGARDING YACHT IN DISTRESS

At 0720, on 28 September, a telex was received from MRCC Falmouth, stating a distress beacon signal had been detected on 406MHz in position 49° 56N, 019° 23W, and requesting all vessels in the area to inform the MRCC. As *Oriana* was about 240 miles away, she responded by passing her position, course, and speed, along with the current weather conditions and ETA.

At 1000, course was adjusted to 077° to proceed directly to the position of the distress beacon but, at 1239, MRCC Falmouth informed *Oriana* that *Atlantic Companion* was proceeding to assist the vessel in distress, and authorised her to stand down from the emergency.

At 1407, the OOW received a radio call from MRCC Falmouth advising that, although *Atlantic Companion* had located a de-masted Canadian yacht, she was having difficulty in evacuating its crew. MRCC Falmouth asked whether *Oriana* would be able to assist if required when she arrived in the area that evening. Immediately the OOW requested the captain to come to the bridge to be appraised of the situation. The captain arrived on the bridge at about 1410, just as the alarm in cabin F178 sounded.

## 1.12 ACTION TAKEN FOLLOWING THE ACCIDENT

### 1.12.1 Temporary Repair

#### a. Windows

After the accident, P&O repositioned all window-panes on decks 5 and 6 which were not properly centred, and fitted steel retaining plates to the corners of all windows on decks 5 and 6 (**Figures 25 and 26**). These plates were fitted on top of the existing glazing strip, with the intention of increasing the overlap and the grip of the frame on the glass. No retaining plates were fitted at the junctions between the mullion and the main part of the frame. This work was proposed by Lloyd's Register as a temporary measure, and carried out by P&O to standards approved by Lloyd's Register.



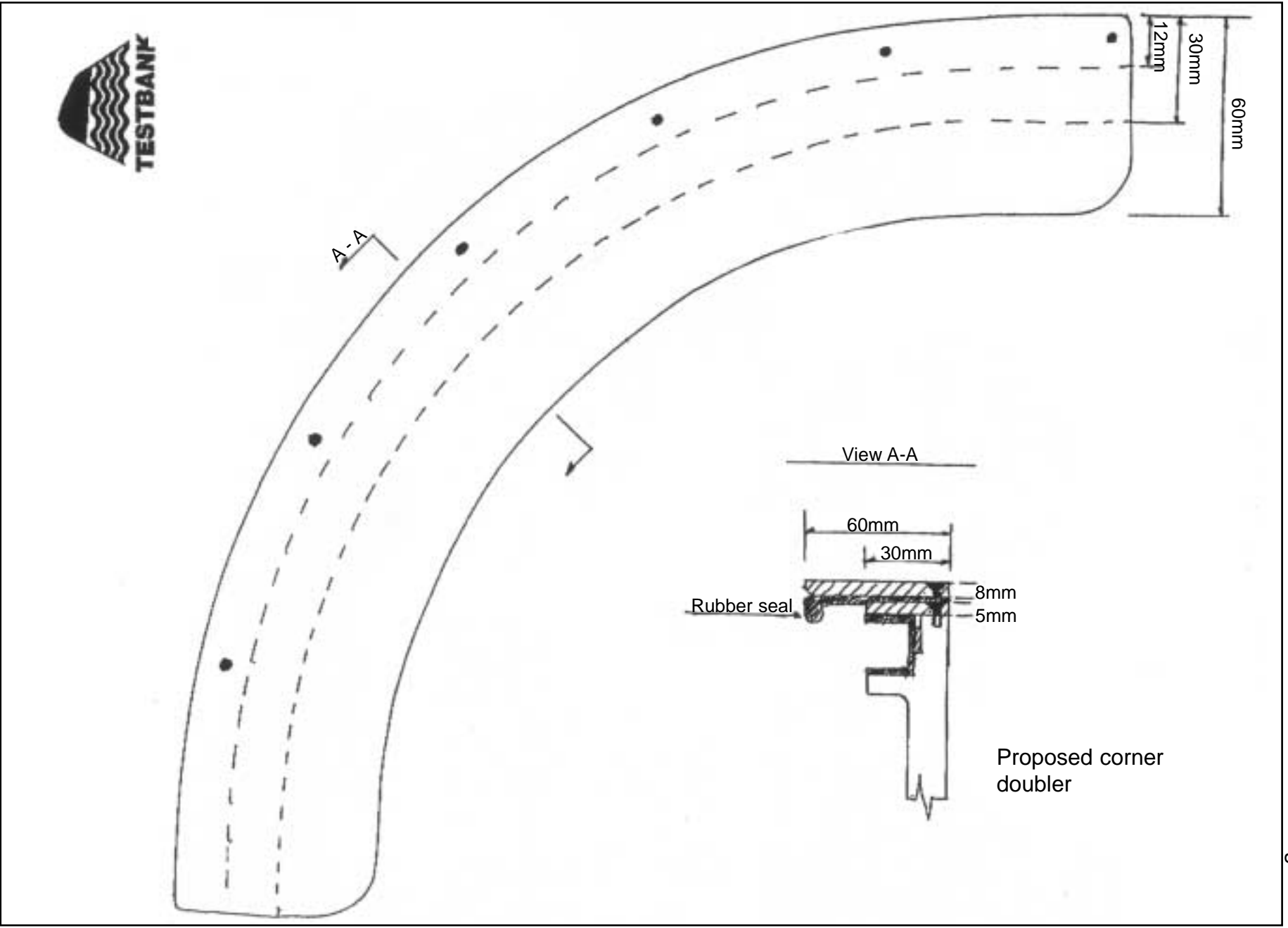

Diagram of retaining plate

Figure 25



Photograph of window fitted with retaining plates

#### b. Storm covers

Following the fitting of retaining plates to the windows, the arrangements for securing storm covers were also modified. To fit the covers, the old lugs are unscrewed, as these are only retained for cosmetic reasons, and replaced with longer studs. Four spacers, the same depth as the retaining plates, are then fitted. The storm cover is then hung on the studs and secured in position by nuts. The new studs, spacers and nuts, are kept with the storm covers, which are generally stowed in crew stairways.

#### 1.12.2 Permanent Repair

Work to rectify the defects, discovered in P&O's survey of the windows on decks 5 and 6 following the accident, was undertaken during the ship's refit in Southampton in December 2000. Where the overlap of the glazing strip over the glass was less than that required by BSMA 25, namely 7mm, larger glass panes were installed by Het Anker. Marks had been scribed on these glass panes 12mm from the edge near the centre of each side, which allowed easy measurement of the overlap of the glazing strip over the glass. Het Anker staff also ensured that Promasil chocks were fitted properly so that the glass panes were centred in the frames. The retaining plates fitted as a temporary measure, were also kept for cosmetic reasons, and should provide additional strength to the windows. In addition to the replacement of the glass panes, on a number of window frames where the threads in the holes for the screws securing the glazing strips had been stripped, new holes were drilled and tapped about 15mm from the original holes, and new glazing strips fitted. A Lloyd's Register surveyor was present while this work was done, and an MAIB inspector saw work in progress on 7 December.

### 1.12.3 P&O

Since the accident, P&O has:

- a. Checked all windows, similar to those breached on *Oriana*, on *Oriana* and other ships in its fleet.
- b. Issued an instruction that storm covers are not to be fitted as a precaution in heavy weather in spaces occupied by passengers or crew.
- c. Issued an amendment to its regulations instructing captains to implement heavy weather precautions, particularly with regard to public areas and elderly passengers, at an early stage.
- d. Issued a further amendment to its regulations instructing captain's to make arrangements to monitor the sea state from positions other than the bridge, particularly in marginal weather and sea conditions.

### 1.12.4 Meyer Werft

By November 2000, the shipbuilder, had taken the following action:

- a. Issued instructions obliging its sub-contractors not to make any changes to structural elements of ships, unless specifically advised to do so.
- b. Intensified the vetting of sub-supplier's work to ensure appropriate regulations and working standards are adhered to.
- c. Reminded classification societies operating in their shipyard of their responsibilities.
- d. Reminded its workforce that if class-related items are changed, they must be re-inspected by a class surveyor, and records of such incidents must be kept.

### 1.12.5 Lloyd's Register

Lloyd's Register has issued a Marine Division Technical Notice to all its offices to provide guidance on the potential problem of window frames becoming oversize because of distortion caused when welded to the ship's side, and the dimensional checks that should be carried out following installation (**Figure 27**).

In August 2001, the Rotterdam office of Lloyd's Register introduced procedures to ensure that its surveyors at the Het Anker factory are able to monitor product quality (**Figure 28**).

### 1.12.6 Het Anker

Het Anker has reviewed key components of its windows, such as the glazing strips, which they consider to be the weak points of the window design.

| RECORD OF PROPOSAL FOR MARINE TECHNICAL NOTICE   |                                |                    |               |                                      |             |
|--|--------------------------------|--------------------|---------------|--------------------------------------|-------------|
| Proposal (1)   |                                |                    |               | Technical Notice No:                 | ...../..... |
| Topic:   | INSTALLATION OF SHIP'S WINDOWS |                    |               | (MSPM) Reference:                    |             |
| Description & Reasons:   |                                |                    |               |                                      |             |
| <p>1. Recent examinations and recorded damages to windows has indicated a common failure mode, which is directly related to the installation process.</p> <p>2. Frame distortion, due to welding, significantly reduces the overlap between the glazing material and the internal glass-retaining strip. In a number of recorded cases this has resulted in the complete glass plane detaching from the frame often without damage to the glazing material.</p> <p>3. The window manufacturer's/builder's documented procedures for installation into ship are to be agreed by the LR Site Surveyors and adhered to.</p> <p>4. Dimensional checks at ship are to be carried out by surveyors in order to confirm that a satisfactory overlap between glazing material and retaining strip is assured on all edges of the window.</p> |                                |                    |               |                                      |             |
|  |                                |                    |               |                                      |             |
| Agreement to Proposal (with signature & date)  |                                |                    |               |                                      |             |
| Proposer:  |                                | Manager of Group:  |               | Date draft proposal received in RDD: |             |
| Review (2)   |                                |                    |               |                                      |             |
| Date   | Comment                        | Signature          | Date          | Comment                              | Signature   |
|  |                                |                    |               |                                      |             |
|  |                                |                    |               |                                      |             |
|  |                                |                    |               |                                      |             |
| Agreement to Issue (with signature & date)   |                                |                    |               |                                      |             |
| Manager of Group:  |                                | Head of RDD Proc.: | D.T. Boltwood | Classification Manager:              | P. Koller   |
|  |                                |                    |               | Marine Director:                     | A.G. Gavin  |
| <p>(1) To include comprehensive background to the reasons for initiating MTN. In addition, comprehensive references to changes in relevant technical publications to be detailed.</p> <p>(2) Draft MTN to be supplied together with the proposed changes to the MSPM or other relevant technical publications.</p>   |                                |                    |               |                                      |             |
| FORM 2604 (09/00)  |                                |                    |               | Research & Development Department    |             |



## MEMORANDUM

Date:

20 August 2001

From:

LR ROTTERDAM

Pete Mast

Our ref:

To:

LR LONDON

Attn: Mike Gudmunsen

Your ref:

MSG/DAPP/ST/MJG/O-251

Subject:

**Survey Procedure ship's windows**

**Survey Procedure for ship's windows and postholes at "Het Anker" BV at Schelluinen, The Netherlands**

1. Visual examination of glazing and verification of certificates.
2. Verification thickness and fire resistance (A30/ A60) of glazing material.
3. At random verification of dimensions.
4. Visual examination of window frames after welding and grinding
5. Verification centre position of window in frames (earlier by fire resistant spacers, now additional by means of markings on glazing).
6. Witness pressure and leak-test to appropriate pressure.
7. For abnormal size windows pressure / leak-testing are specially considered.

## **SECTION 2 - ANALYSIS**

### **2.1 WINDOW DESIGN**

The design of the windows fitted on *Oriana* is not identical to the drawings issued with the type approval. However, as the drawings are generically the same, it is considered the window design met the requirements of the regulations.

The type approval certificate did not allow the use of mullions. Mullions, however, could be accepted by the MCA on a case by case basis, provided it could be shown they were of adequate strength. Although there is no evidence of any application for approval of mullions in *Oriana's* case, the absence of distortion to the mullions following the accident, indicates that they were of sufficient strength.

To provide maximum strength, glazing strips should ideally be fitted on the outside. This allows the pressure load on a window, caused by a wave, to be taken on the frame rather than the glazing strip. As in *Oriana*, however, where access to the windows from the outside for maintenance is extremely difficult, the glazing strips are usually fitted on the inside. The MAIB is not aware of any passenger cruise ships where this is not the case. BSMA 25 does not specify which side the glazing strip should be fitted.

BSMA 25 provides the design standard for frames and retaining systems up to glass thickness of 19mm and up to length and breadth of 1100mm x 800mm respectively. Although the windows on deck 6 were 1100mm x 1000mm, the glass used was 15mm thick, which is well below the maximum of 19mm. It is considered, therefore, that the application of BSMA 25 in this instance was appropriate. The windows on deck 5 were fitted with 19mm glass, and because mullions were fitted, they were well within the size range shown in BSMA 25. The strength of the glass fitted to the damaged windows on decks 5 and 6 was sufficient to resist the pressure required by BSMA 25.

In summary, the design of the windows on decks 5 and 6 was close enough to the windows approved by the MSA to be acceptable.

### **2.2 WINDOW DEFECTS**

#### **2.2.1 General**

A consequence of oversize frames and window-panes not being properly centred was that the glazing strips did not overlap the glass by at least 7mm, as required by BSMA 25. This reduced the strength of the windows, which was further reduced by glazing strips not clamping the glass properly because gaskets either were too thick, or of incorrect size, and damaged screws being

used. As these defects were widespread on the windows throughout decks 5 and 6, it is highly probable that similar defects were present on those damaged. This is supported by the marks found on two of the panes which remained intact.

Oversize frames are only problematic if insufficient overlap of the glass edges with the glazing strip results. Had the glass been manufactured to provide the designed overlap of about 13mm, the detrimental effect on the overlap caused by the oversize frames would have been less significant. Because many of the glass panes fitted had been manufactured to provide the minimum overlap required by BSMA 25, oversize frames inevitably resulted in an overlap below that required by the standard in many of the windows.

Each of the latent defects discovered by P&O immediately following the accident might not have been particularly detrimental to the strength of the windows on its own, but it is considered their cumulative effect made them significantly weaker than designed. It is therefore possible that a number of windows were weaker than required by BSMA 25.

The difference in the appearance and hardness of the gaskets was probably because gaskets fitted below lifeboat and liferaft-launching arrangements had to be fire resistant, whereas those fitted elsewhere did not.

### 2.2.2 Defects originating during manufacture

Some window deficiencies could have been the result of sub-standard manufacture and assembly at the Het Anker factory. If this was the case, they were not detected either by Het Anker's quality control system, or by the Lloyd's Register surveyor during his visits to the factory in 1993 and 1994. None of the latent defects, later discovered by P&O, were identified during this period. This implies that either the defects were not present, or that the quality assurance and inspection procedures were inadequate.

All of the glass panes fitted should have had chamfered edges. The illustration of the dimensions of arris for the edges of the glass panes in BSMA 25 clearly shows the edges to be chamfered. *Oriana's* windows, however, were delivered with rounded edges, which it is considered would have made them marginally more prone to being forced from the frames. It is considered that this defect should have been detected by both Het Anker and Lloyd's Register.

Although there are differences between P&O's and Het Anker's measurements of the glass panes on decks 5 and 6, the fact that many of the glass panes were not large enough to allow the as-designed overlap of 13mm (by scaling the drawing) with the glazing strip remains. However, as the glass panes facilitated the minimum overlap of 7mm, the windows still met with the standard required by BSMA 25 in this respect, provided the glass was centralised in the frames.



### 2.2.3 Defects during and after installation

#### a. Oversize frames.

The windows were delivered to the shipyard as assembled units, and were welded into position while the ship was on a level building berth. If the frames were oversize when they were delivered to the shipyard, oversize openings would have had to be cut to accommodate them. The fact that the shipyard has no knowledge of oversize openings being made, supports the possibility that the oversize frames resulted from the welding process, despite the fact chain welding techniques might have been used.

It is also possible that as most cruise ships tend to hog when they are afloat, the resultant bending of the hull girder following launch, could have led to the stretching of some window frames. This would have been at a maximum near amidships where the bending moment is greatest, and where the window 16mm oversize in cabin F178 was located. However, any distortion caused in this way would probably have been minimal.

#### b. Defects

The removal, and subsequent refitting, of the glass panes in the shipyard could have been the source of several of the window defects, particularly if non-specialists had undertaken the work. When replacing the glass panes, the importance of using chocks to centre the glass might have been overlooked and, if new gaskets had been fitted which were thicker than the originals, screws might have been over-tightened, causing them to shear or causing damage to the screw heads. It is also possible that some original screws might have been lost and been replaced with screws of incorrect length. The requirement to hose-test the windows would not have identified such defects because this is only a test for leakage; no significant loading is placed on the windows during hose testing.

### 2.2.4 Origin of defects

During visits by MAIB inspectors to the Het Anker factory on 14 December 2001, and the Meyer Werft shipyard on 25 January 2002, the standard of workmanship and quality control at both sites appeared to be high. The origin of the defects detailed in **paragraph 1.7** could not be identified, but must have lay with the window manufacturer, the shipbuilder, or both. The defects had therefore been present prior to *Oriana's* delivery to P&O, but had not been detected.

## 2.3 FAILURE MECHANISM

The MAIB believes the windows breached because of one, or a combination of, the following:

- a. The glass pane was unevenly supported by its frame. Wave impact and pressure head pushed the window-pane out except where it was properly supported. The resultant bending moment close to the supported edge caused the glass to shatter. This failure mode was identifiable, because glass fragments were found under the glazing strips on one side of some windows, and would have appeared as an instantaneous failure as witnessed by some of the occupants of the affected cabins.
- b. The glass pane was unevenly supported by its frame, as above. However, the glass did not break but was forced out of its frame and into the cabin where it either shattered when it hit something in the cabin, or it remained intact.

To have breached the windows on deck 6 and damaged the cabin interiors to the extent illustrated in **Figures 3, 4 and 5**, the wave must have been at least 10m high and must have impacted with force. As waves possibly as high as 13m were observed shortly before the window breach (**Figure 11**), it is feasible that *Oriana* was struck by a wave with a force exceeding the designed window strengths. This might have been particularly so if *Oriana* was struck by a breaking wave, which exerts a greater force than a static wave of the same length.

It has not been possible, however, to determine if the failure of the windows was caused by a wave, the force and static pressure head of which, was greater or less than those required by BSMA 25. The MAIB has no evidence that other windows complying with this standard have failed in service. This, along with the fact that the impact was neither heard nor felt by the crew on the bridge, nor caused a deflection to the ship's head, lends weight to the argument that the wave might not have exceeded the requirements of BSMA 25.

Regardless of whether the wave that struck did, or did not, exceed the statutory strength requirements, the MAIB considers that, had the windows been manufactured and installed as designed, they would have been more likely have been able to withstand the force exerted by the wave.

## 2.4 STORM AVOIDANCE

Ships are not expected to alter course to try to avoid every depression they encounter. The intensity of a depression, wind strength, sea and swell height and direction, the size and seaworthiness of the vessel, and the purpose of the voyage, are among many factors to be considered before taking such action.

In this instance, the captain was made aware of the conditions associated with the Atlantic low pressure system in question, via warnings issued from 26 to 28 September by Meteo France and the National Weather Service. In response to the potential discomfort and disruption posed by this weather system, the captain plotted its movement relative to the ship's position and intended track.

Analysis of **Figure 2** indicates the approximate distances between the centre of the depression (Meteo France and Bracknell positions) and the ship on 27 to 28 September were as follows:

| Date/Time | Distance  |
|-----------|-----------|
| 270001    | 950 miles |
| 271200    | 800 miles |
| 280001    | 500 miles |
| 281200    | 420 miles |
| 281410    | 400 miles |

It is evident from the above distances that, from the morning of 28 September, *Oriana* was on the edge of the south-west sector in which the force 10 winds were forecast by NWS. This is supported by the distances between the isobars in **Figure 7**, which indicate a wind strength of about 50 knots in the vicinity of the ship's positions, at 1200 on 28 September, and the recorded barometric pressure and wind speed and direction.

Based on the information and forecasts available on 27 September, the captain assessed that, if the ship continued on her planned route at a reduced speed of 19.5 knots, she would remain clear of the worst of the storm conditions. **Figures 7 and 13** support his assessment, showing conditions to have been marginally more severe towards the centre of the depression. Nevertheless, although the ship remained on the south-western edge of the depression, she continued to close sufficiently to encounter storm force winds and very high seas.

Weather systems are dynamic phenomena, and even though the movement of a depression can be closely monitored, the application of weather forecast information by a moving platform using onboard resources can be problematic. Weather charts are usually very small scale, and lack an accurate means of determining direction. Consequently, the plotting of positions and tracks tends to be approximate. The forecast areas also tend to be large. Although Faraday is not dissimilar in area to that of the UK, and weather will invariably differ in different parts of the area, forecasts tend to give only generalised information. It is unfortunate that satellite-tracking difficulties prevented *Oriana* receiving up-to-date tailored weather forecasts from Bonvoyage, which would have been of

assistance. Despite this, however, the ship received ample weather information from a variety of sources. As the forecasts for areas Faraday and Hecate were similar during 27 and 28 September, the lack of weather forecasts for area Hecate is not considered to have been significant.

## 2.5 SAFETY CONSIDERATIONS

In deciding to continue on a course of 077°, the captain had several factors to consider: the conditions experienced, the conditions expected, the safety of the ship, the safety of personnel, the ETA in Southampton, the yacht in distress, and the alternative options available.

On encountering heavy weather, although wind strength, sea state and wave height are key indicators, ship motion is usually the simplest method to gauge the risks posed by the conditions. When heading directly into large seas at speed, the increased stresses on the hull caused by slamming into the waves invariably gives cause for concern and may force a change in course and/or speed. In this case, the captain's actions were based on the fact that *Oriana* was experiencing a quarter sea and was having no difficulty in coping with the resulting cork-screw motion. This movement might have been uncomfortable or disconcerting to some passengers, and would have increased the risk of injury to personnel if adequate precautions were not taken. However, it should not normally have endangered the structural integrity of the ship. Furthermore, the weather forecasts received for area Faraday indicated a gradual improvement in the conditions.

From *Oriana*'s bridge, an observer looks down to the sea from a height of about 27m. From this perspective, the vertical dimension of a wave is condensed, and the sea may appear flatter than it actually is. Also, the motion experienced by a ship the size of *Oriana* in high seas is much less than that experienced by smaller vessels, particularly when the ship's roll is dampened by the use of stabilisers, and can lead to an under-estimation of the sea state or make the presence of occasional larger waves less obvious. The captain, however, had observed the sea conditions from various levels, ranging from deck 5 to the bridge. Such observations would have reduced the possibility of an under-estimation of the sea conditions, had they been viewed from the bridge alone.

ETAs are important to passenger ships. If they are not met, berths need to be re-booked, following cruises rescheduled, and passengers' onward travel reorganised, all of which involve expense and disruption. It follows, therefore, that the captain would have felt some responsibility to arrive in Southampton as planned. Notwithstanding this, as the captain was prepared to delay the ship's ETA by reducing speed on the evening of 27 September, there is no evidence to suggest that the ship's timely arrival in Southampton was a greater consideration than her safety. The captain, however, would not have wanted to be later than absolutely necessary. Although the option of turning to a more

'down sea' course would have reduced ship movement and increased passenger comfort, as it did following the accident, it was thought to be unnecessary and would have meant steering away from the yacht in distress. It would also have considerably delayed the ship's arrival in Southampton. A further reduction in speed was also an option but, had this been considered to have been required by the conditions, it is likely that the stabilisers would have been less effective and the frequency of the waves passing the vessel would have increased, making ship motion more violent. Furthermore, as the wave causing the damage probably came from the port quarter, a reduction in speed would not have decreased the relative velocity between the wave and the ship at the time of impact. It is considered, therefore, that a speed of 19.5 knots was appropriate in the conditions, and did not contribute to the damage sustained.

## **2.6 RISK TO PERSONNEL**

The precautions of restricting access to exposed areas, advising passengers to take care when moving about the ship, closing dead-lights, and fitting storm covers over appropriate windows, were aimed at minimising the risk of injury to personnel. Such actions are similar to precautions taken by many ships in heavy weather. The advice to elderly passengers to avoid the conservatory on deck 12, however, was made in response to accidents to passengers caused by the movement of the ship. When a ship rolls, the movement of the deck is more pronounced on the higher decks. Such movement might not be considered to be uncomfortable to a mariner, but probably would be to elderly passengers not used to ship movement. It is therefore possible that the risk of injury to elderly persons in this area could have been foreseen, and the advice given sooner. Also, it would have been prudent to have ensured that the stock in the shops was secured before deck movement became sufficient to dislodge these items, not after.

## **2.7 STORM COVERS**

The original design of the storm covers showed the material used to be 5mm unstiffened aluminium plate, which was accepted by the MCA. It is apparent, however, that the material used was 4mm stiffened aluminium plate. Although no written evidence is available to show that this revision was accepted by the MCA, the MAIB considers that the strength of the two constructions would have been similar.

Ideally, storm covers should be fitted on the outside of windows, to protect the glass. A wave impacting on a cover secured in this manner will tend to force the cover on to the frame, making the strength requirements of the securing arrangements less critical. However, where access to the outside of windows is not practical, as was the case for the breached windows in *Oriana* and windows fitted in all known passenger cruise ships, storm cover mountings must be located on the inside of the window.

Storm covers can be fitted in anticipation of heavy weather, as the numbers that are required to be carried possibly suggest, or they can be used to close off openings after a window has been breached. Which of these applications is intended by the regulations is unclear, and may possibly change depending on whether storm covers are fitted internally or externally. If storm covers are intended to be fitted before heavy weather, they should be at least as strong, but preferably stronger, than the window. If they are not, a wave breaking a window would also probably dislodge the storm cover. Alternatively, if storm covers are intended to blank off openings left by breached windows, the strength of the covers and associated securing arrangements is not so critical, providing the relevant interior spaces remain unoccupied.

In *Oriana's* case, the storm covers were fitted to some windows on deck 5 as additional protection against the heavy weather, but failed at the same time as the windows. This was because of inadequate securing arrangements. The dislodged storm covers could have caused severe injuries to the occupants of the affected cabins on deck 5, more so than the toughened safety glass from the windows, which is designed to shatter into small pieces.

The MAIB considers that the intended use of storm covers requires clarification and, if storm covers are to be fitted on the inside of windows as a precaution against heavy weather, more detailed guidance on strength requirements needs to be issued. It is understood the MCA is considering a proposal by Lloyd's Register to waive the requirement for storm covers where double-glazed windows are fitted and both the inner and outer windows meet the requirements of BSMA 25.

The MAIB is not satisfied that the new securing arrangements in *Oriana* will make the storm covers stronger than the windows they are designed to cover. Therefore, these covers are considered to be suitable for use following a window breach when the spaces they are protecting can be left unoccupied; they are not suitable to act as a precaution in heavy weather.

## **2.8 DAMAGE REPAIRS**

It is considered that the crew responded very effectively to the breached windows. The formation of three teams to deal with the emergency, enabled the openings to be closed quickly. The attendance at the RN damage repair course by two of the officers involved probably helped significantly in this respect. It is considered that, through frequent and comprehensive broadcasts, the captain kept the passengers fully informed throughout the incident.

## **2.9 REMEDIAL ACTION**

The action proposed by Lloyd's Register and undertaken by P&O to the standard required by Lloyd's Register to centre the glass panes, and fit retaining plates on all the windows on decks 5(F) and 6(E), was appropriate as a temporary measure. The work undertaken during the ship's refit in December 2000 is considered to be a satisfactory permanent solution.

## **2.10 ACTIONS TAKEN FOLLOWING THE ACCIDENT**

The MAIB considers the actions taken by P&O, Lloyd's Register, Meyer Werft, and Het Anker following the accident were necessary, and should help prevent similar occurrences in the future.

## **2.11 TRENDS IN SHIP'S WINDOW DESIGN**

During this investigation, it was apparent that windows much larger than those fitted in *Oriana*, were being manufactured and installed on a number of cruise ships under construction. While it is considered that the size range detailed in BSMA 25 covers the windows fitted in *Oriana*, it does not cover these larger windows, some of which contain 25mm glass. The MAIB assumes that, as these windows are outwith the standard, window manufacturers must be extrapolating data contained in BSMA 25 or equivalent standards, or working to their own standard. This is not satisfactory, and the MAIB considers that the standard for windows requires revision. Such revision should also take into account changes in technology and window design, and could also incorporate the requirements for storm covers, addressing the problems with the current requirements already mentioned in this report.



## SECTION 3 - CAUSE

### 3.1 IMMEDIATE CAUSE:

Sea water ingress was caused by a large wave hitting and breaching three windows fitted with storm covers on deck 5(F), and 3 windows on deck 6(E).

### 3.2 CONTRIBUTING FACTORS:

1. The cumulative effect of various defects made many of the windows significantly weaker than designed, and a number possibly weaker than required by BSMA 25.[2.2]
2. Many windows did not meet the requirement of BSMA 25 in respect of the overlap of the glass pane and the glazing strips being at least 7mm. This was due to a combination of oversize frames, glass panes not being properly centred, and the dimensions of the glass panes supplied.[2.2.2]
3. None of the latent defects, which might have been caused during manufacture, were found by a Lloyd's Register surveyor during inspections of *Oriana's* windows at the Het Anker factory during 1993 and 1994.[ 2.2.2]
4. Oversize frames were probably the result of distortion caused when the windows were welded into the ship's side.[2.2.3]
5. Some of the window defects might have been caused by incorrect refitting of glass panes in the shipyard, following their removal.[2.2.3]
6. The origin of the latent window defects discovered by P&O as soon as practically possible following the accident must have lay with the window manufacturer, the shipbuilder, or both.[2.2.4]
7. Although speed was reduced to avoid encountering the conditions at the centre of the depression, the ship still experienced storm force winds and very high seas.[2.4]
8. The wave causing the damage was probably larger than 10m high and possibly impacted with a force greater than the designed strength of the windows.[2.3]
9. Had the windows been manufactured and installed as designed, they would have been more likely to have been able to withstand the pressure exerted by the wave.[2.3]
10. The storm cover mounting arrangements were of inadequate strength.[2.7]
11. There is little guidance on the intended use and strength of storm covers. [2.7]

### 3.3 OTHER FINDINGS:

1. The window design met the requirements of the regulations.[2.1]
2. Although there is no evidence of any application for approval of mullions in *Oriana's* case, the absence of distortion to the mullions following the accident, indicates that they were of sufficient strength.[2.1]
3. Distortion of window frames caused by hogging was minimal.[2.2.3]
4. The window defects were not evident when the windows were hose tested. [2.2.3]
5. The absence of forecasts for area Hecate is not considered to be significant. [2.4]
6. Although tailored weather information was not received from Bonvoyage because of satellite tracking problems caused by the weather, the ship received ample weather information from various other sources.[2.4]
7. Although the height of *Oriana's* bridge, along with the overall size of the ship, and the use of stabilisers, could potentially have contributed to an under-estimation of the sea conditions, the captain's observations from various levels would have reduced this possibility.[2.5]
8. A speed of 19.5 knots was appropriate with the sea and swell on the port quarter, although a more 'down-sea ' course might have reduced ship movement and been more comfortable for the passengers.[2.5]
9. The evidence indicates that the ship's ETA in Southampton was not a greater consideration than her safety.[2.5].
10. Advice to elderly passengers regarding the use of the conservatory restaurant could have been given earlier.[2.6]
11. Action to secure loose items in the shops, could have been taken earlier.[2.6]
12. The dislodged storm covers could have caused more severe injuries than the shattered windows.[2.7]
13. Although the new securing arrangements make the storm covers supplied in *Oriana* suitable for use following a window breach when the spaces they are protecting can be left unoccupied, they are not suitable to act as a precaution in heavy weather.[2.7]

14. The attendance of two of *Oriana's* officers on the RN damage control course was beneficial.[2.8]
15. The crew responded very effectively to the breached windows and the openings were quickly closed.[2.8]
16. The passengers were kept fully informed throughout the incident.[2.8]
17. The window repairs proposed by Lloyd's Register and undertaken by P&O to the standard required by Lloyd's Register are considered to be satisfactory. [2.9]
18. The actions taken by P&O, Lloyd's Register, Meyer Werft, and Het Anker following the accident were necessary, and should help prevent similar occurrences in the future.[2.10]
19. Some windows being fitted in cruise ships are larger than the sizes covered in BSMA 25.[2.11]

## SECTION 4 - RECOMMENDATIONS

**Het Anker**, the manufacturers of *Oriana's* windows, is recommended to:

1. Continue to review quality control systems to eliminate the possibility of the defects found in *Oriana's* windows occurring in future products.

**Meyer Werft**, the shipbuilder is recommended to:

2. Continue to review quality control systems to eliminate the possibility of the defects found in *Oriana's* windows occurring in future products.

**Lloyd's Register** is recommended to:

3. Monitor its inspection and surveying practices at window manufacturers and shipyards to ensure that window defects are quickly identified and rectified.
4. Ensure that when glass is removed from frames in a shipyard, it is refitted in the presence of a Lloyd's Register surveyor, and properly recorded.
5. Check any windows, similar to those breached on *Oriana*, which are fitted to ships in other fleets.

**The Maritime and Coastguard Agency** is recommended to:

6. Provide clarification on the intended use of storm covers on passenger ships.
7. Provide more detailed strength requirements for storm covers carried on passenger ships, if they are intended to be fitted in anticipation of heavy weather.
8. Investigate the revision of the existing standard for windows, taking into account their increasing size, and new technology.

**Marine Accident Investigation Branch**  
**November 2002**

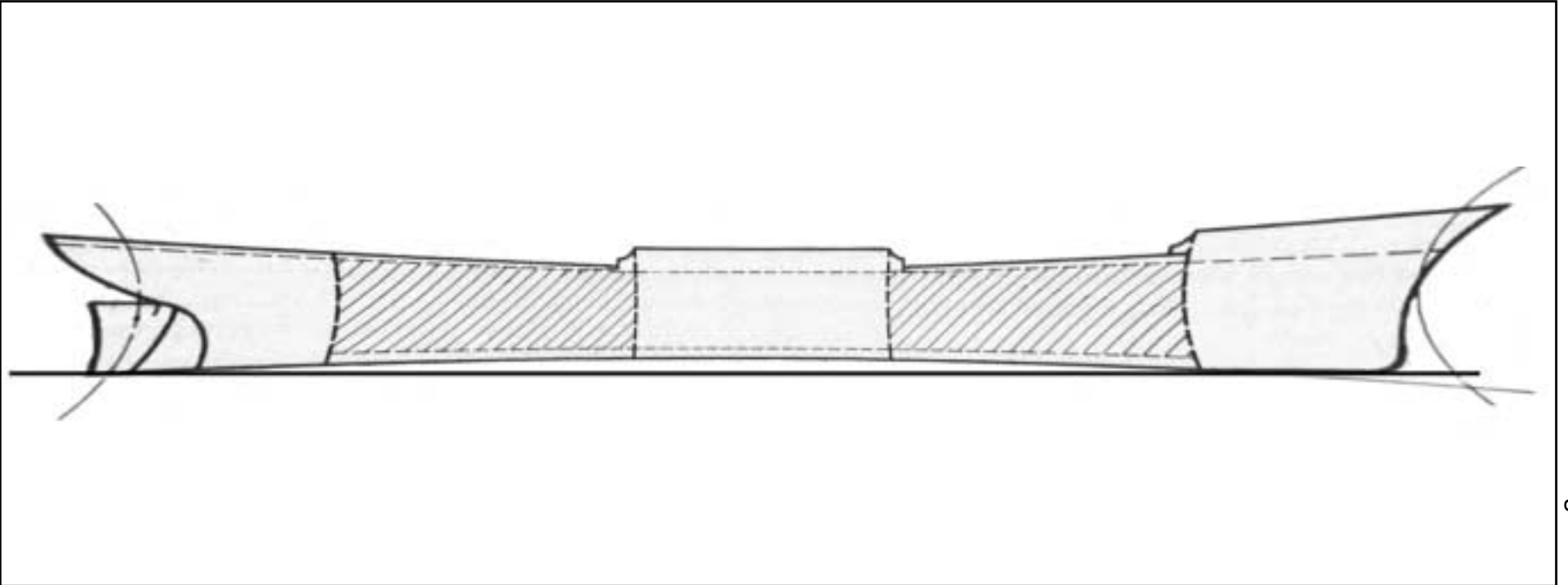

Figure 28

Illustration of hogging

**Appendix – Definitions of Sea and Swell Heights, and Wind Strengths**

|                           |            |   |            |
|---------------------------|------------|---|------------|
| a. Length of swell waves: | Short      | - | 0 - 100m   |
|                           | Average    | - | 100 - 200m |
|                           | Long       | - | over 200m  |
| b. Height of swell waves: | Low        | - | 0 - 2m     |
|                           | Moderate   | - | 2 - 4m     |
|                           | Heavy      | - | over 4m    |
| c. Height of sea waves:   | Rough      | - | 2.5 - 4m   |
|                           | Very Rough | - | 4 – 6m     |
|                           | High       | - | 6 – 9m     |
|                           | Very High  | - | 9 – 14m    |

Beaufort wind scale:

| Number<br>Height | Descriptive Term | Mean Velocity | Probable Wave |
|------------------|------------------|---------------|---------------|
| 7                | Near gale        | 28 – 33 knots | 4 – 5.5m      |
| 8                | Gale             | 34 – 40 knots | 5.5 – 7.5m    |
| 9                | Strong gale      | 41 – 47 knots | 7 – 10m       |
| 10               | Storm            | 48 – 55 knots | 9 – 12.5m     |